



SCAS Judges Presentation

Prepared by Hannah Brown and Katy Lipscomb and
using the work of Alojz Mauser.

Dedicated to the memory of Guy Ely – an original SCAS Judge,
and Alan Jones.

Contents



- General Information
- Details of Archery Rounds
- Field Checking
- Target / Boss Checking
- Equipment Checking
- Judge Duties
- Clout Archery
- Head to Heads
- Additional Information

- This presentation has been designed to be an aid to new Judges to help them on their way and to help them understand the duties and responsibilities of being a Judge. Therefore in some places more experienced Judges may feel it is lacking in detail.
- **It is in no way designed to replace the Rule Books and Handbooks already in place - the Rule Books should always take precedence.**
- We have tried to make sure this presentation covers the basics of Archery GB and World Archery, however if you feel something is inaccurate or missing please let us know so we can update the next version.
- Full credit must go to Alojz Mauser on whose original presentation this work is based.



Chapter 1 - General Information

Golden Rules



- **Relax and Enjoy yourself** – remember this is supposed to be fun, and if you enjoy yourself the archers will enjoy themselves too.
- **Always try to be fair** – whenever you make a decision try to make sure it is fair and that no archer is unfairly advantage or unfairly disadvantaged. Be protective not punitive and give the benefit of the doubt.
- **Use the Rules** – always be careful to make sure you use the Rule Book and never make up a rule particularly when it comes to penalties. Try to always bear in mind the intention of a rule when applying it, it will help you when apply it.

Levels of Judging

- **Candidate Judge/Candidate Youth Judge** – the beginning grade where most of the learning is done. After a minimum of judging 12 tournaments (which must include 1 Indoor, 1 Target and 1 Field/Clout/Flight shoot) and have attended a Candidate Seminar you can apply to become a County Judge.
- **County Judge/Youth Judge** – whilst the learning continues the hard work begins to kick in in-order to gain experience. You must be prepared to be Judge in Charge of tournaments up to and including County Status. After a minimum of judging 18 tournament (which must include 3 World Record Status shoots, 3 Record Status shoots, 2 Indoor shoots and include 1 Target and 1 Field/Clout/Flight) and have attended one Regional Judges Conference, one AGB Judges Conference and a Regional Judge Seminar you can apply to become a Regional Judge.
- **Regional Judge** – this is where you need to work hard to gain experience and expand your knowledge to the next level. This is also the level where you need to develop your skills at helping the tournament organiser and more junior level Judges. You must be prepared to be Judge in Charge of tournaments up to and including World Record Status (without a Head to Head). After a minimum of 25 Judging days (must include 10 World Record Status shoots or National Tournaments, 2 should be Head to Head tournaments, also 4 Indoor Tournaments and a minimum of 1 Field/Clout/Flight and 1 Target shoot) and have attended one AGB Judges Conference in the previous 3 years you can apply to become a National Judge.

Levels of Judging

- **National Judge** – this level is mainly about helping to develop more junior level Judges and being the Judge in Charge at tournaments. You must be prepared to be Judge in Charge of tournaments up to and including National Status and World Record Status (with Head to Head).
- **Youth Judge (World Archery only)** – National Judges who are between 18 – 30 years old can apply for this, Youth Judges are appointed to Youth Championships, Youth Olympics and other International Youth Events
- **Continental Judge (World Archery Europe only)** – after a minimum of two years of being a National Judge you can apply to become an World Archery Europe / Continental Judge. People who have been awarded the title World Archery Judge Emeritus are also classed as Continental.*
- **Candidate International Judge / World Archery Accredited Judge (World Archery Only)** – after two years at Continental Level depending on experience you can apply to become a Candidate International Judge*
- **International Judge (World Archery only)** – International Judges are appointed by the World Archery Judge committee*
- * there is a total limit of 9 Continental, IJC and IJ Judges allowed per Country

Levels of Judging

- A Judge who fails their assessment must wait a minimum of 6 months before applying to be assessed again
- Candidate Judges who do not pass their County assessment within 3 years will be removed from the list of Judges
- County and Regional Judges who do not pass their next assessment within 2 years of first taking the assessment will need to fulfil the qualifying criteria again
- Applications for National Assessment must be made before the 30th October, to be assessed in the following year
- There are also re-accreditation periods for County, Regional and National Judges which last 4 years. Re-accreditation is dependant on achieving a certain level of work, attending conferences and completing an open book paper.

Do's – from the Judges Handbook

- This is not an exhaustive list, always try to keep in mind the image you portray to other people and act accordingly, let common sense be your guide.
- **Do's**
 - Wear the uniform with pride in your right to wear it, and with the purpose of making a positive contribution to the tournament.
 - Think of yourself as a host welcoming guests.
 - Be enthusiastic, courteous and friendly.
 - Apply the rules fairly, consistently and firmly.
 - Offer polite assistance to all; archers, guests, spectators, media personnel and fellow officials.
 - Wait until an archer has come off the line before passing a message to them.

Don'ts – from the Judges Handbook

- **Don'ts**

- Allow your attention to wander from your primary duty which is the competition.
- Imply disrespect for competitors by smoking, drinking or eating while engaged in official duties like arrow calling or equipment inspection.
- Chat at length with other officials whilst on duty, an act that may lead others involved to believe that you are not paying proper attention to your assigned duties.
- Fraternise too much with the competitors, it may be difficult to penalise someone you are too friendly with.

Don'ts – from the Judges Handbook

- Speak to an archer on the shooting line until he has finished shooting, unless it is for a safety problem.
- Drink any alcoholic beverage on or near the tournament field before or during the competition.
- Carry a camera or 'Walkman'/MP3 player while on duty.
- Use a mobile telephone on the tournament field. If you must carry one, ensure that it is in silent mode.
- Spend periods of time among the competitors. Everyone must be able to find you.

Dress Code

- Judge's must try to set an example of the dress code to others and must at all times follow the rules. The details of the Judges Uniform can be found on the Judge's section of the website, including details on how to order the uniform
- New Candidates are not expected to have the uniform straight away, however they must have it by the time they qualify as a County Judge. In the mean time they can wear smart green and white, or smart trousers and a white polo shirt. If you are not sure on what you can wear, please ask the JLO

Judging Equipment

- A Judge should always try to be prepared for any situation, but as a minimum it is advisable to carry the following (* = advisable but not necessary to start with).
 - Magnifying Glass – not too big and that gives good magnification (2 to 4 times).
 - Pens – at least two red pens, a blue and/or black pen, pencil and a rubber.
 - Tape measure – a minimum of 3 metres, but over time it is good to also get a 30m tape for indoors and a 100m tape for outdoors.
 - A whistle – at least one whistle is needed which can be heard from a distance.
 - Stop watch – one which you can use and read easily and quickly.
 - Rule Book – these are electronic, so make sure you have the latest version downloaded.

Judging Equipment

- Note book – for making notes about lost arrows etc.
- *Compound Bow Scales – these should always have a recent calibration certificate.
- *Binoculars – compact design.
- *Pliers / Tools – to help with repairs and removing of piles from bosses.
- *Red and Yellow cards – these are needed in Head to Heads and Teams events.
- *Divider – for measuring arrows for World Archery Ties and Best Golds.
- *122mm ring – for checking Barebows.

Mentoring

- Within SCAS Judging we try to match new Judges with a Mentor who is a more experienced Judge.
- The new Judge can either choose a Mentor for themselves or have one chosen for them by the JLO based upon location and compatibility.
- The Mentor Scheme is designed to help a new Judge by giving them support and help when they need it and helping them to progress through the Judging Levels.
- This support may be in the form of being at the end of a phone when needed, to helping the new Judge find shoots and judging with them. It all depends on what the Judge feels they need and varies from person to person.

How to get shoots

- One of the most difficult things for a new Judge to do is to get into shoots. Some tips are
 - Ask local Judges whom you respect if they have any shoots you could come along and observe, it is always advisable to start with small local shoots rather than a World Archery Star.
 - Look through Archery UK and websites to find nearby shoots that you want to attend, then contact both the organiser and the Judge in Charge to see if they are happy for you to attend.
 - It is important to try to work with as many different Judges as possible so you can see how other people do things and learn from them. Also try to go to a range of shoots, both indoors and outdoors.
 - Contact the Judge Liaison Officer or the Chairman Of Regional Judges Committee to see if there are any SCAS tournaments you can attend.
 - Do not be put of if someone turns you down, some shoots are not very good for a brand new Judge to attend, for example a Head to Head competition or a shoot where the Judges will be too busy to spend time with you.
 - Also be prepared to fund your own expenses, some tournament organisers do not offer expenses to Candidate Judges. The same applies to refreshments.

SCAS Judge's Committee

- The SCAS Regional Judge Committee is made up of a Chairman, Vice-Chairman and a Judge Liaison Officer (JLO). Posts are elected every 3 years at the SCAS Judge's meeting, so one year the JLO is up for election/renewal, the next year its the Chairman and the next Vice - Chairman.
 - **Chairman** – The Chairman's duties are to assist the JLO in all their duties, to Chair the Annual Judge's Meeting and to be an additional contact point for SCAS Judges.
 - **Vice - Chairman** – The Vice -Chairman's duties are to assist the JLO and Chairman in all their duties, to stand in for the JLO or Chairman if needed and to be an additional contact point for SCAS Judges.
 - **JLO/Secretary** – The JLO's duties include organising the Annual Meeting, act as a point of contact between the region and the Judge's Working Group, appoint Judges to SCAS shoots, organise and co-ordinate Judge training and assessments and to be the main point of contact for both Judges and non-Judges.

J05 Booklet

- All Judges below National Grade who want to progress further in Judging need to have a J05 Form completed for them at each tournament they attend as a Judge.
- The J05 should always be filled in accurately to reflect the Judge's performance.
- The J05 not only acts as a record of where you have been and when but also has room for the 'assessing' Judge to complete comments on what you have done during the day and what progress you have made in your Judging career.
- For example a previous J05 might comment that you did an announcement for the first time and it was okay but you need to work on it. The Judge at the next shoot will read this and work with you to improve your announcements and allow you to practice them.

J5 Booklet

- The J5 is not designed to be a 'School Report' but to act more as a record of your strengths and weaknesses so other Judges can concentrate on helping you improve certain areas. There is also room for you to make any comments you wish on the J5, for example if something strange happened or feel you dealt with a certain situation very well.
- Your previous J5s should be presented to the Main Judge, before the start of the shoot. They will then look through them and either complete them themselves at the end of the shoot or ask another Judge to complete one for you. You should try to get as many different Judges to complete your J5 as possible to give a well rounded view of your abilities.
- If you are the only Judge at a tournament ask the Organiser to complete one for you as a record of your day.



Chapter 2 – Details of Archery Rounds

Archery GB Outdoor Rounds

- General Information
 - The Outdoor Archery GB Rounds are split into Imperial and Metric Rounds.
 - All Archery GB Rounds have 1 end of 6 sighters before each round.
 - All Archery GB Rounds are shot on 122cm faces except for the Short Metric and the two nearest distances of the Metric and Half Metric Rounds.
 - All Archery GB Rounds have 6 arrows per end except for the Short Metric and the two nearest distances of the Metric and Half Metric Rounds which can have 6 or 3 arrows per end.

Archery GB Outdoor Rounds

- There are 2 options for timing Archery GB Rounds

Option 1

- Where 6 arrows are shot in an end Archer A shots 3 arrows and then leaves, Archer B then goes on the line and shots 3 arrows, then Archer A returns to the line to shot 3 arrows then finally Archer B returns to the line to shot their final 3 arrows.
- Archers should rotate positions between ends.
- The maximum time to shot 3 arrows is 2 ½ minutes.
- One sound signal will signal the start of shooting and three sound signals will indicate the end of the end and be the signal to advance to the targets.

Archery GB Outdoor Rounds

Option 2

- Two sound signals for the first detail to take their positions on the line
- After 10 seconds one sound signal for shooting to commence
- After 4 minutes (if shooting ends of 6), 2 minutes (if shooting ends of 3), or when the shooting line is clear two sound signals will be given for the next detail to take their place.
- After 10 seconds one sound signal for shooting to commence
- When all details have shot then 3 sound signal are given to indicate the archers are to advance to the targets.
- An archer shooting before or after their time will lose their highest scoring arrow(s) of that end, and they will be scored as a Miss.
- Traffic Lights / Countdown clocks can be used if wanted, if they are then they will give a 30 second amber warning.

Archery GB Outdoor Rounds

- Scoring

- Archery GB Imperial Rounds

- Gold – 9
- Red – 7
- Blue – 5
- Black – 3
- White – 1

- Archery GB Metric Rounds

- Inner 10 – Record as X, score value 10
- Inner Gold – 10
- Outer Gold – 9
- Inner Red – 8
- Outer Red – 7
- Inner Blue – 6
- Outer Blue – 5
- Inner Black – 4
- Outer Black – 3
- Inner White – 2
- Outer White – 1

- A miss is recorded as an M.

Archery GB Outdoor Rounds

- Ties

- Archery GB Imperial Rounds

Award Based On	1 st Tie Break	2 nd Tie Break
Score	Hits	Golds
Hits	Score	Golds
Golds	Score	Hits

- Archery GB Metric Rounds

Award Based On	1 st Tie Break	2 nd Tie Break
Score	Xs	10s Only
Tens (inc Xs)	Xs	Score

Archery GB Outdoor Imperial Rounds

308(b)(iii)	Round	100y	80y	60y	50y	40y	30y	20y	15y	10y
*	York	6	4	2						
*	Hereford		6	4	2					
*	Bristol I		6	4	2					
*	Bristol II			6	4	2				
*	Bristol III				6	4	2			
*	Bristol IV					6	4	2		
*	Bristol V							6	4	2

Archery GB Outdoor Imperial Rounds

(iii) 308(b)	Round	100y	80y	60y	50y	40y	30y	20y	15y	10y
	St. George	3	3	3						
	Albion/Long Windsor		3	3	3					
	Windsor			3	3	3				
	Windsor 50				3	3	3			
	Windsor 40					3	3	3		
	Windsor 30						3	3	3	
	New Western	4	4							
	Long Western		4	4						
	Western			4	4					
	Western 50				4	4				
	Western 40					4	4			
	Western 30						4	4		

Archery GB Outdoor Imperial Rounds

iii) 308(b)	Round	100 y	80y	60y	50y	40y	30y	20y	15y	10y
*	American			2 ½	2 ½	2 ½				
	St Nicholas					4	3			
	New National	4	2							
	Long National		4	2						
	National			4	2					
	National 50				4	2				
	National 40					4	2			
	National 30						4	2		

Archery GB Outdoor Imperial Rounds

i) 308(b)(ii)	Round	100y	80y	60y	50y	40y	30y	20y	15y	10y
	New Warwick	2	2							
	Long Warwick		2	2						
	Warwick			2	2					
	Warwick 50				2	2				
	Warwick 40					2	2			
	Warwick 30						2	2		

Archery GB Outdoor Metric Rounds

(ii) 308(b)(i)	Round	90 m	70 m	60 m	50 m	40 m	30 m	20 m	15 m	10 m
*	Metric I		3	3	3		3			
*	Metric II			3	3	3	3			
*	Metric III				3	3	3	3		
*	Metric IV					3	3	3		3
*	Metric V						3	3	3	3
	Long Metric 90	3	3							
	Long Metric 70		3	3						

Archery GB Outdoor Metric Rounds

ii) 308(b)(i)	Round	90 m	70 m	60 m	50 m	40 m	30 m	20 m	15 m	10 m
	Long Metric I		3	3						
	Long Metric II			3	3					
	Long Metric III				3	3				
	Long Metric IV					3	3			
	Long Metric V						3	3		

Archery GB Outdoor Metric Rounds

i) 308(b)(ii)	Round	90 m	70 m	60 m	50 m	40 m	30 m	20 m	15 m	10 m
	Short Metric				3		3			
	Short Metric I				3		3			
	Short Metric II					3	3			
	Short Metric III						3	3		
	Short Metric IV							3		3
	Short Metric V								3	3

Archery GB Outdoor Metric Rounds

i) 308(b)(ii)	Round	50m	40m	30m	40m	30m	Additional Rules
		122 cm face			80cm face		
	Metric 122-50	6					
	Metric 122-40		6				
	Metric 122-30			6			
	Metric 80-40				6		Full size or 6 zone
	Metric 80-30					6	Full size or 6 zone

Archery GB Outdoor Metric Rounds

i) 308(b)(ii)	Round	70m	60m	50m	40m	30m	20m	10m
	900 70	2½	2½	2½				
	900 50			2½	2½	2½		
	900 40				2½	2½	2½	
	900 30					2½	2½	2½

Archery GB Outdoor Rounds

- 308(b)(i) & (ii)**

The following Table show which rounds in the previous tables can be shot for National Record Purposes. Single records can be claimed for all rounds with a letter. Please see the rules for the latest information

TABLE 3-4	Group Letters as shown in column 1 of Tables 3-1, 3-2, 3-2A and 3-3		
Age group	Archery GB Record Group		WA Record Group
Men/Open	A	Open	Men
Women	B	Female	Women
Under 21 Men/Open	C	Junior Open	Under 21 Men
Under 21 Women	D	Junior Female	Under 21 Women
Under 18 Men/Open	E	Junior Open	Under 18 Men
Under 18 Women	F	Junior Female	Under 18 Women
Under 16 Men/Open	G	Junior Open	Under 18 Men
Under 16 Women	H	Junior Female	Under 18 Women
Under 15 (Men/Open and Women)	I	Junior Open or Junior Female	Under 18 Men or Women
Under 14 (Men/Open and Women)	J	Junior Open or Junior Female	Under 18 Men or Women
Under 12 (Men/Open and Women)	K	Junior Open or Junior Female	Under 18 Men or Women
50 + Men/Open	L	50+ Open	50+ Men
50 + Women	M	50+ Female	50+ Women

- 308(b)(iii)**

Double records can be claimed for all rounds with a * in column 2 in the tables.

Archery GB Age

- An archer may compete in a junior age group where the tournament take place up to and in the year of their birthday prior to the limit on the category. (e.g. if they turned 17 in a year they can compete in an U18 category, but they cannot turn 18 in the year)
- An archer may compete in the 50+ division when the competition takes place in the year of their 50th Birthday and thereafter.

World Archery Outdoor Rounds

- General Information
 - All World Archery Rounds have a period of practice before the competition. It will last for a maximum of 45 minutes. During practice archers can shoot as many arrows as they want in the time. The ONLY exception is a Double 720 Round where practice is only before the first round.
 - In World Archery Rounds for distances of 90, 70, 60 and 50m(for Under 18 Women) 122cm faces are used, for 50, 40 (for Under 18 Women) and 30m 80cm faces are used. For 30m 80cm centres can be used.
 - In World Archery Rounds for distances of 90, 70, 60 and 50m(for Under 18 Women) ends of 6 arrows are shot (they are all shot one after the other), for 50, 40 (for Under 18 Women) and 30m ends of 3 arrows are shot.
 - The maximum time to shot 6 arrows is 4 minutes and to shot 3 arrows it is 2 minutes. The exact timings for World Archery are covered later in the document.

World Archery Outdoor Rounds - Scoring

- Inner 10 – Record as X, score value 10
- Inner Gold – 10
- Outer Gold – 9
- Inner Red – 8
- Outer Red – 7
- Inner Blue – 6
- Outer Blue – 5
- Inner Black – 4
- Outer Black – 3
- Inner White – 2
- Outer White – 1

- For 80cm centre faces the scoring can from 10 to 5
- A miss is recorded as an M.

World Archery Outdoor Rounds - Ties

- All ties which are non-critical (i.e. one's that don't decide who will progress to the next stage of the competition in a Head to Head) are resolved by :-
 - Greatest number of X's
 - Greatest number of 10's
 - If both of these are equal then they are declared equal, their positions in Match Play charts will be decided by a disc toss.

World Archery Outdoor Rounds - Ties

- All ties which are critical (i.e. one's that decide who will progress to the next stage of the competition in a Head to Head or medal placements) are resolved by a shoot off :-
 - Both archers shoot one arrow. The arrow nearest the middle wins.
 - If the arrows are the same distance from the centre then the process can be repeated
 - More details of this rule can be found in the World Archery Rule Book – Book 3 14.5.2.2

World Archery Outdoor Rounds

iii) 308(b)	Round	90 m	70 m	60 m	50 m	40 m	30 m	20 m	15 m	10 m
*	1440	3	3		3		3			
*	1440		3	3	3		3			
	1440			3	3	3				
	900			2 ½	2 ½	2 ½				
	70m		6							
	60m			6						
	50m (Compounds)				6 (80cm face)					
*	WA Standard				3		3			

Archery GB Indoor Rounds

- General Information
 - All Archery GB Rounds have 2 ends of 3 sighters.
 - The faces that are allowed are :-
 - Full size – 80cm, 60cm and 40cm.
 - Multiple faces – 60cm Triple Triangular, 60cm Triple Vertical, 40cm Triple Triangular, 40cm Triple Vertical.
 - The maximum time to shot 3 arrows is 2 ½ minutes for non-Record Status shoots and 2 minutes for Record Status shoots.
 - For non-Record Status shoots one sound signal will signal the start of shooting and three sound signals will indicate the end of the end and be the signal to advance to the targets.
 - For Record Status shoots World Archery timings are used details of which can be found later on.

Archery GB Indoor Rounds - Scoring

Zone	Compound Bows	Non-compound bows
Inner 10	10	10
Inner Gold	9	10
Outer Gold	9	9
Inner Red	8	8
Outer Red	7	7
Inner Blue	6	6
Outer Blue	5	5
Inner Black	4	4
Outer Black	3	3
Inner White	2	2
Outer White	1	1

- When using multiple centre faces if more than one arrow is found in a face, only the lowest arrow value will score, the remaining arrow(s) are scored as miss(es).
- A miss is recorded as an M.

Archery GB Indoor Rounds - Ties

Award Based On	1st Tie Break	2nd Tie Break
Score	10s	9s
Hits	Score	10s
10s	Score	Hits

Archery GB Indoor Rounds - Vegas

- Everything remains the same as other Indoor Archery GB rounds apart from :-
 - Faces – Is a 40cm triangular face, but each face must be numbered, 1 = lower left, 2 = top of the triangle and 3 = lower right. There should be 4 faces per boss.
 - Shooting - There is no rotation, the first two archers shoot on the higher targets, the second two shoot on the lower targets, after 30 arrows the archers who were shooting at the top targets shoot at the bottom targets and the ones on the bottom targets move to the top targets.
 - It is shot in ends of 3 and there are two ends of three arrows for sighters.
 - Arrows – Arrows should be numbered and shot in ascending numerical sequence, one arrow in each face in the order 1, 2 and 3. So the lowest numbered arrow goes in face 1, the next one in face 2 and the highest numbered arrow in face 2.
 - Scoring – An arrow shot out of order or hitting a target face other than the one it was supposed to will be scored as a Miss (M).

Archery GB Indoor Rounds

– Vegas 300

- Everything remains the same as other Indoor Archery GB rounds apart from :-
 - Faces – Is a 40cm triangular face with any colour background. There should be 4 faces per boss.
 - Shooting - There is no rotation, the first two archers shoot on the lower targets, the second two shoot on the higher targets, after 15 arrows the archers who were shooting at the lower targets shoot at the higher targets and the ones on the higher targets move to the lower targets.
 - It is shot in ends of 3 in two minutes and there are two ends of three arrows for sighters. Method 2 timing will be used.
 - Arrows – a maximum diameter of 10.7mm can be used for this round only.

Archery GB Indoor Rounds

– Vegas 300

- Scoring – The scoring zones are 10 – 6. An arrow hitting the smaller circle in the 10 ring shall score an X and count as a 10. This applies to all bow types, not just compounds.
- Score totals – They should include score, number of 10s and number of Xs
- Ties – Ties will be decided by
 - Score
 - Number of 10s
 - Number of Xs

Archery GB Indoor Rounds - Worcester

- Everything remains the same as other Indoor Archery GB rounds apart from :-
 - Faces – Is 16in in diameter – a circle in the centre 3.2in in diameter ringed by 4 concentric bands of 1.6in. The centre is white and the four bands black and divided by white lines. There is also the option of having a 5 centre face which is the 5 and 4 zone from the full size face. If this is used the normal rules apply if there is more than one arrow in a face.
 - Shooting - There is no rotation, the first two archers shoot on the higher targets, the second two shoot on the lower targets, after 30 arrows the archers who were shooting at the top targets shoot at the bottom targets and the ones on the bottom targets move to the top targets. The archers who shoot at the top faces shoot first.
 - It is shot in ends of 5 in a maximum time of 4 minutes and there is one end of 5 arrows for sighters.
 - There are 12 ends (60 arrows).
 - Scoring – The scoring is 5, 4, 3, 2, 1 and M.

Archery GB Indoor Rounds

– Worcester X-Ring

- Everything remains the same as the Worcester apart from :-
 - Faces – A 5 centre face which is the 5 and 4 zone from the full size face but with an “x-ring” which is 4cm in diameter. If this is used the normal rules apply if there is more than one arrow in a face.
 - Other face colours and backgrounds apart from the traditional black and white are allowed as long as the scoring zone dimensions are the same.
 - Scoring – An arrow in the “x-ring” will be recorded as an X and count as a 5.
 - Ties – If archers are tied on score, hits and 5 count then the X count will determine the highest ranked archer.

Archery GB Indoor Rounds

See 405 (b)(ii)	Distance	30m	20y	20y	25y	20y	18m	
	Face Size	80 cm	60 cm	40 cm	60 cm	16 in	40 cm	Additional Rules
	Bray I			2 ½				Full face size or triple
	Bray II				2 ½			Full face size or triple
	Stafford	6						Full face size only
*	Portsmouth		5					Full size,5 zone or triple
*	Worcester					5		Special face and rules
	Vegas 300			2 ½				Special face and rules
	Vegas						5	Special face and rules

- 405(b)(ii) - Double records can be claimed for all rounds with a * in column 1.

World Archery Indoor Rounds

- General Information
 - All World Archery Rounds have a period of practice before the competition. It will last for a maximum of 45 minutes. During practice archers can shoot as many arrows as they want in the time. However due to multiple sessions Indoors it is advisable just to have 2 ends of practice instead.
 - The faces that are allowed are
 - Full size – 60cm and 40cm.
 - Multiple faces – 60cm Triple Triangular, 60cm Triple Vertical, 40cm Triple Triangular, 40cm Triple Vertical.
 - There are also versions of the vertical faces with either only the Compound 10 ring or the Recurve 10 ring. These don't tend to be used in the UK – Check carefully that the correct faces are used on each match.
 - For 25m distances the 60cm faces will be used, for 18m distances the 40cm faces will be used.
 - The maximum time to shoot 3 arrows is 2 minutes. The exact timings for World Archery are covered later in the document.

World Archery Indoor Rounds - Scoring

Zone	Compound Bows	Non-compound bows
Inner 10	10	10
Inner Gold	9	10
Outer Gold	9	9
Inner Red	8	8
Outer Red	7	7
Inner Blue	6	6
Outer Blue	5	5
Inner Black	4	4
Outer Black	3	3
Inner White	2	2
Outer White	1	1

- When using multiple centre faces if more than one arrow is found in a face, only the lowest arrow value will score, the remaining(s) arrows are scored as miss(es).
- A miss is recorded as an M.

World Archery Indoor Rounds - Ties

- All ties which are non-critical (i.e. one's that don't decide who will progress to the next stage of the competition in a Head to Head) are resolved by :-
 - Greatest number of 10's (inner 10's for compounds).
 - Greatest number of 9's.
 - If both of these are equal then they are declared equal, their positions in Match Play charts will be decided by a disc toss.

World Archery Indoor Rounds - Ties

- All ties which are critical (i.e. one's that decide who will progress to the next stage of the competition in a Head to Head or medal placements) are resolved by a shoot off :-
 - The centre faces on vertical faces and the top face of triangular faces will be used.
 - Both archers shoot one arrow, the arrow nearest the middle wins.
 - If the arrows are the same distance from the centre then the process can be repeated
 - More details of this rule can be found in the World Archery Rule Book – Book 3 14.5.2.2

World Archery Indoor Rounds

(b)(ii) See 405	Distance	18m	25m	
	Face Size	40cm	60cm	Additional Rules
	18m Round	5		Full size or triple face
	25m Round		5	Full size or triple face
	Combined	5	5	Full size or triple face
	Match Round	1		Triple faces only

- 405(b)(ii) - Double records can be claimed for all rounds with a * in column 1.

Other Rounds

- There are lots of other rounds / types of archery, information is available in the Archery GB / World Archery Rule Books
 - Popinjay – Archery GB
 - Clout – Archery GB and World Archery
 - Field Archery – Archery GB and World Archery
 - 3D Archery – World Archery
 - Flight – Archery GB and World Archery
 - Ski-Archery – World Archery
 - Run Archery – World Archery
- You can also have club rounds, these are basically rounds made up by the a club to be shot at the club or for fun. These can be any number of arrows, at any distance at any face. Club rounds are not eligible for National records or Record Status, but they must be shot to Archery GB rules.



Chapter 3 – Field Checking

Refer to Part 3

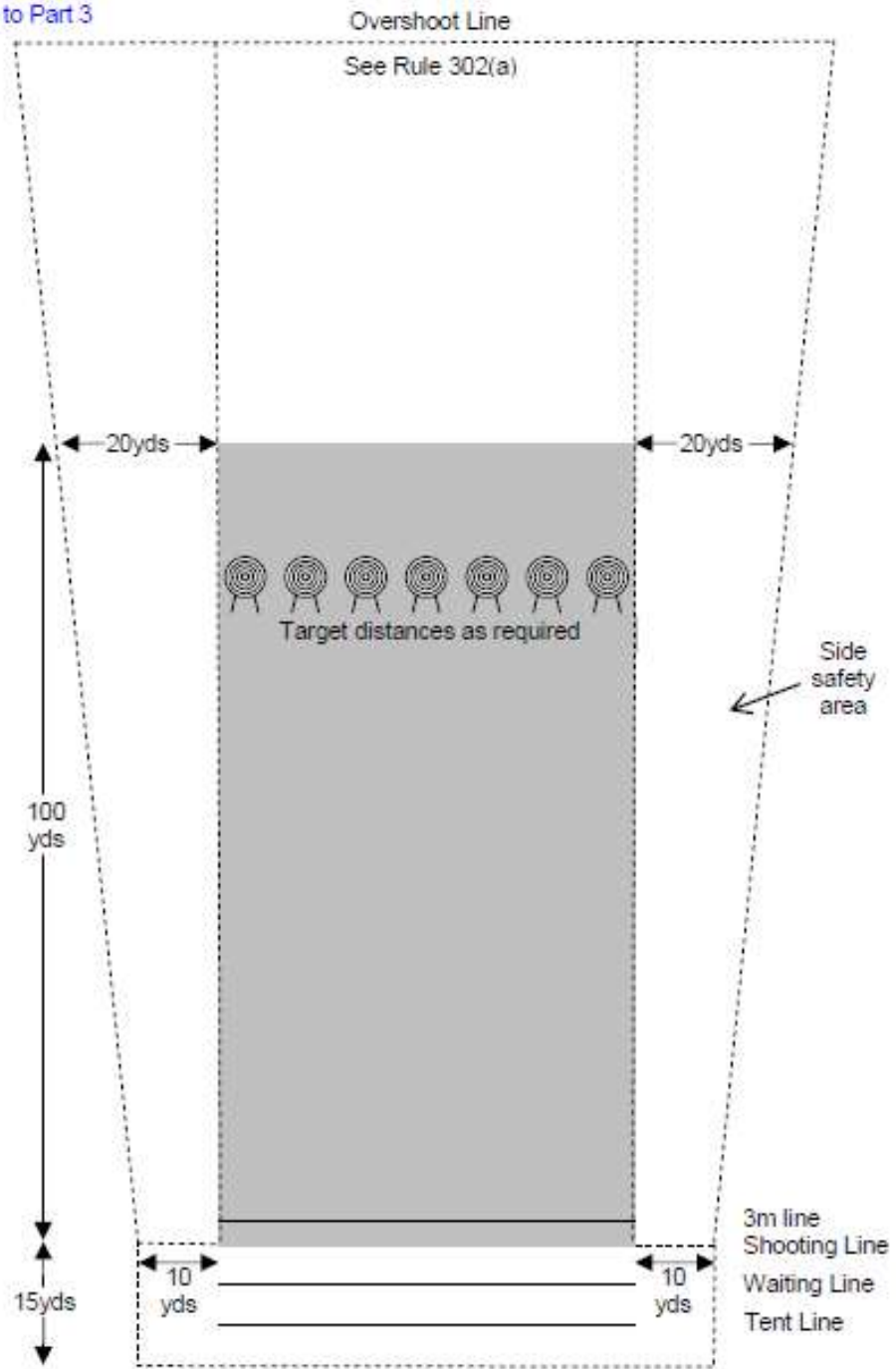

Archery GB Range Layout - Safety Rule 302

Archery GB Range Layout - Safety

- At all events the Archery GB Range Layout rules apply for insurance purposes. The World Archery Range Layout does not apply to shoots in the UK
- Where two adjacent ranges are in use independently, the safety area between the two ranges must be a minimum 20 yards and fully roped off, and no access allowed until both ranges have finished shooting.
- Both World Archery and Archery GB allow the safety distances to be reduced if there is suitable backstopping, such as an impenetrable hedge, an earth bank, suitable netting etc.
- Indoors – If in a conventional building then the walls and roof meet the safety requirements. However arrangements must be made to prevent access through any point in front of the shooting line or within the overshoot or side safety areas whilst shooting is in progress.

Range Layout - Safety

- Other points to consider when checking a ground are :-
 - Are there any gaps in the perimeter? – walk round the field looking for points of entry such as gates, holes in fences, nearby rights of way, penetrable hedges and tree lines. Remember that for Insurance purposes all fields are considered accessible by the public.
 - What is behind the targets? – Are there any potential distractions in the archers line of site behind the targets, such as a path way.
 - What direction are the archers shooting in? – In an absolutely ideal world the archers should be shooting North but this is not a requirement, just an ideal.
- If you have any concerns regarding the safety of the field, you should talk to the Chief Judge and the Tournament Organiser so a solution can be found. Most problems can be resolved.

Range Layout - General

- Other things to look for on a field are :-
 - *Car Park Location* – are people going to cut across the shooting area to get between their cars and the shooting line.
 - *Toilets* – How far away and how many of them are there and are there disabled facilities – this may affect how long the breaks need to be.
 - *Refreshments* – What is available and how far away are they – this may affect how long the breaks need to be.
 - *Additional Equipment* – Are there plenty of spare bosses, stands and faces available and are they nearby. Also are there any metal detectors available to help find lost arrows.
 - *Emergency Equipment* – Is there a First Aider and a First Aid box available and where are they.
 - *Director of Shooting Location* – For World Archery rounds is the DOS Stand in the right place to give a good view of the shooting line and the field.

Range Layout - General

- All Archery Ranges, even if they are only used once a year must be registered with Archery GB.
- As Judges we should request to see the Range Registration Certificate. This will give details of any dispensation that might have been given, for example due to a wall to shorten the overshoot.
- We must still check the field thoroughly and be confident the Range is safe to use.

How to Measure a Field

- In order to check a field the first thing you need is a tape measure that is long enough – if you do not have one, ask to borrow one from the organiser.
- You always measure to and from the middle of the lines, apart from the 3m line which must all be within the 3m.
- When measuring to the targets you measure to a point directly underneath the middle of the target.
- It is best to firstly check the distances in front of the target, so the 3m line and the distances of the round and also check for squareness.
- Then check the distances behind the shooting line, so the waiting line and tent line.
- Then check the overshoot and safety distances.
- When measuring the field measure in several places along the line to make sure the distances are correct all the way along.
- Be careful when measuring long distances that the tape measure stays straight, it is easy for them to end up a bit bent and twisted over long distances.

How to Measure a Field

- Laser Measures
 - Make sure that the tolerances on them meet the tolerances in the Rule Books, some of them have very large tolerances (particularly those at the lower end of the market) and these should not be used for the official measuring
 - Only use them for tournaments where the targets are not going to move. For example, they are perfect for Indoors, Field and 3D events. However, they should not be used for Target tournaments where the targets are going to be moved, for example at a York or 1440. At these tournaments you cannot check all the distances with a laser as the targets are not in position, so a tape must be used to check all the distances before the tournament starts.

Checking the Field is Square

- There are many ways to check the squareness of the field. The most popular however is Pythagoras
 - Measure from the corner of the field (point A) 40m along the shooting line and mark point B.
 - Then measure from point A 30m up the field and mark point C.
 - If the field is square the distance between point B and point C will be 50m.
 - The process should then be repeated on the opposite diagonal corner of the field to ensure squareness.

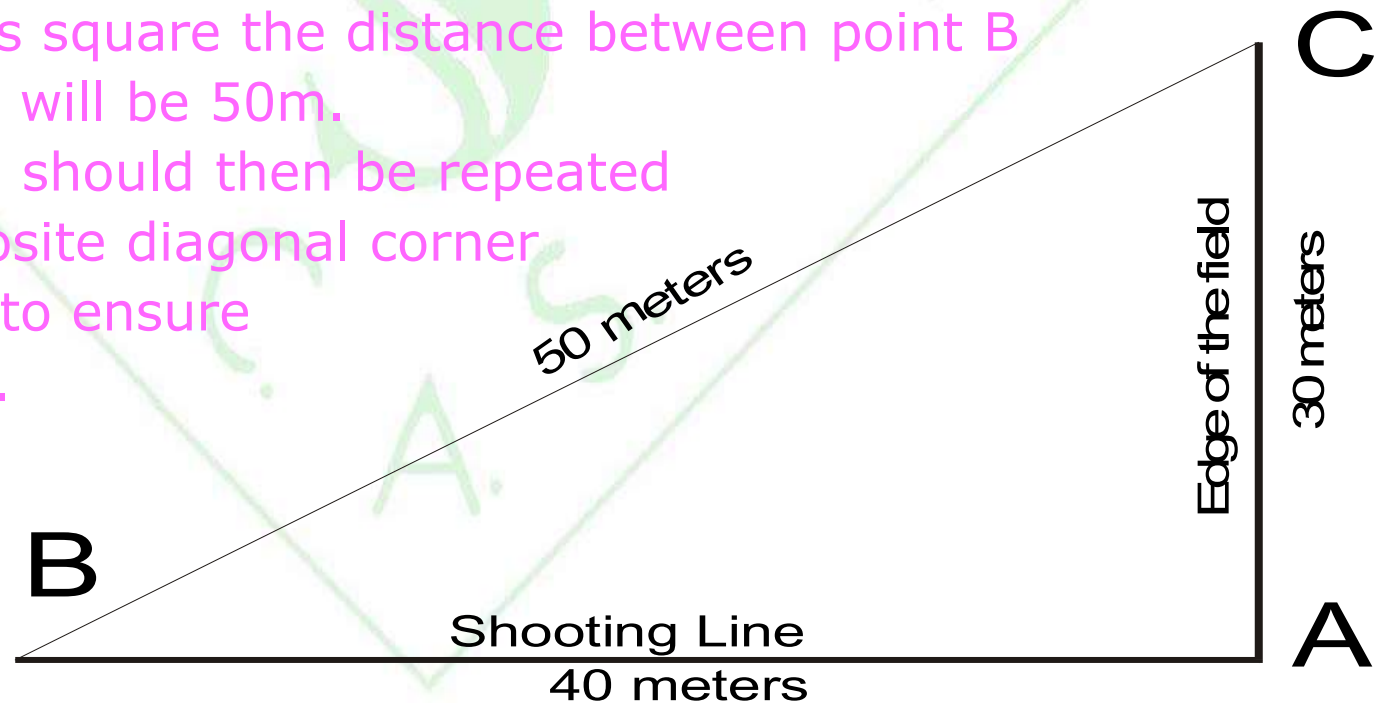

Tolerances on Distances

Archery GB

- Outdoor
 - Up to and including 50m ± 15 cm
 - Above 50m ± 30 cm
 - Up to and including 50yds ± 6 in
 - Above 50yds ± 12 in
- Indoor
 - Imperial rounds ± 4 in
 - Metric rounds ± 10 cm

World Archery

- Long Distances
 - Up to and including 50m ± 15 cm
 - Above 50m ± 30 cm
- Short Distances
 - 18m / 25m ± 10 cm

Lines on a Field – Archery GB

• OUTDOOR

- Target Line
- 3m Line **
 - All in 3ms of the shooting line
- Shooting Line
 - The target numbers should be marked on the shooting line
 - The minimum spacing between target centres for when one or two archers are on the line together it is 2.5m (8ft 2ins). When three archers are on the line together it is 3.66m (12ft)
- Waiting Line
 - 5yds behind the shooting line
- Equipment Line
 - 10yds behind the shooting line
- Lanes **
 - To hold 1 to 3 targets

** - These lines are optional but a 3m line is required for Record Status World Archery Rounds

• INDOOR

- Target Line
- 3m Line **
 - All in 3ms of the shooting line
- Shooting Line
 - The target numbers should be marked on the shooting line
 - The minimum spacing between target centres is a minimum of 80cm (2ft 8in) per archer
- Waiting Line
 - 5yds behind the shooting line but can be reduced to 3yds
- Equipment Line
 - 10yds behind the shooting line
- Lanes **
 - To hold 1 to 3 targets

** - These lines are optional but a 3m line is required for Record Status World Archery Rounds

Lines on a Field – World Archery

• OUTDOOR

- Target Line
- 3m Line
 - All in 3ms of the shooting line
- Shooting Line
 - The target numbers should be marked on the shooting line and shooting positions
 - The minimum spacing is 90cm per archer
- 1m Line **
 - Used for Team Events, 1m behind the shooting line
- Media Line **
 - 1m before the Waiting Line
- Waiting Line
 - 5m behind the shooting line
- Equipment Line
 - 10m behind the shooting line
- Lanes
 - To hold 1 to 3 targets

** - These lines are optional

• INDOOR

- Target Line
- 3m Line
 - All in 3ms of the shooting line
- Shooting Line
 - The target numbers should be marked on the shooting line
 - The minimum spacing is 70cm per archer
- 1m Line **
 - Used for Team Events, 1m behind the shooting line
- Media Line **
 - At least 3m from the Shooting Line
- Waiting Line
 - 3 or 4m behind the shooting line
- Equipment Line
 - 10m behind the shooting line
- Lanes **
 - To hold not more than two archers

** - These lines are optional

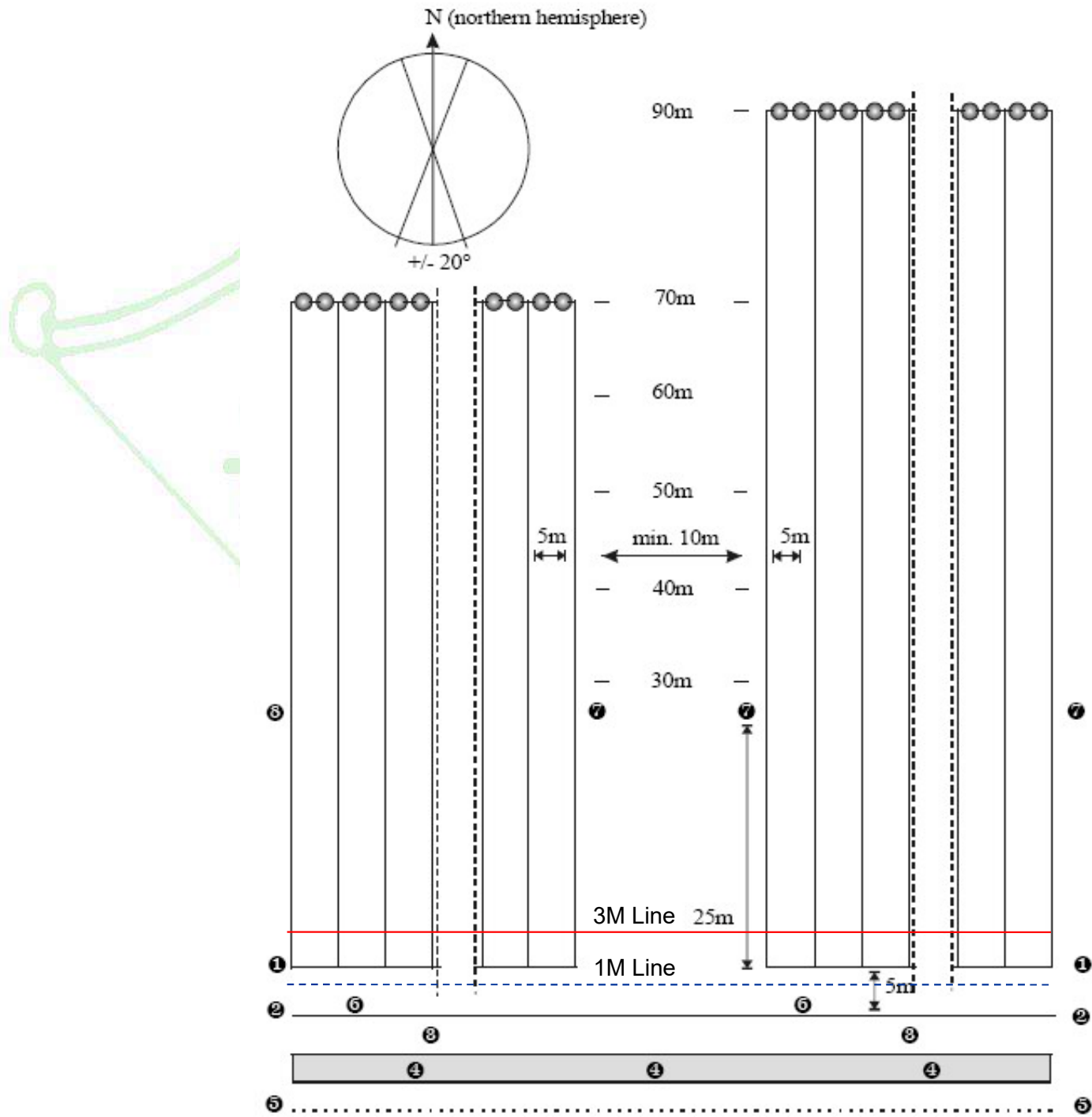

Example of a World Archery Field Layout

- ① SHOOTING LINE
- ② WAITING LINE
- ③ EQUIPMENT AREA
- ④ COMPETITORS AREA
- ⑤ SPECTATORS BARRIER
- ⑥ JUDGES SEATS
- ⑦ LIGHTS/DIGITAL CLOCKS
- ⑧ DOS STAND

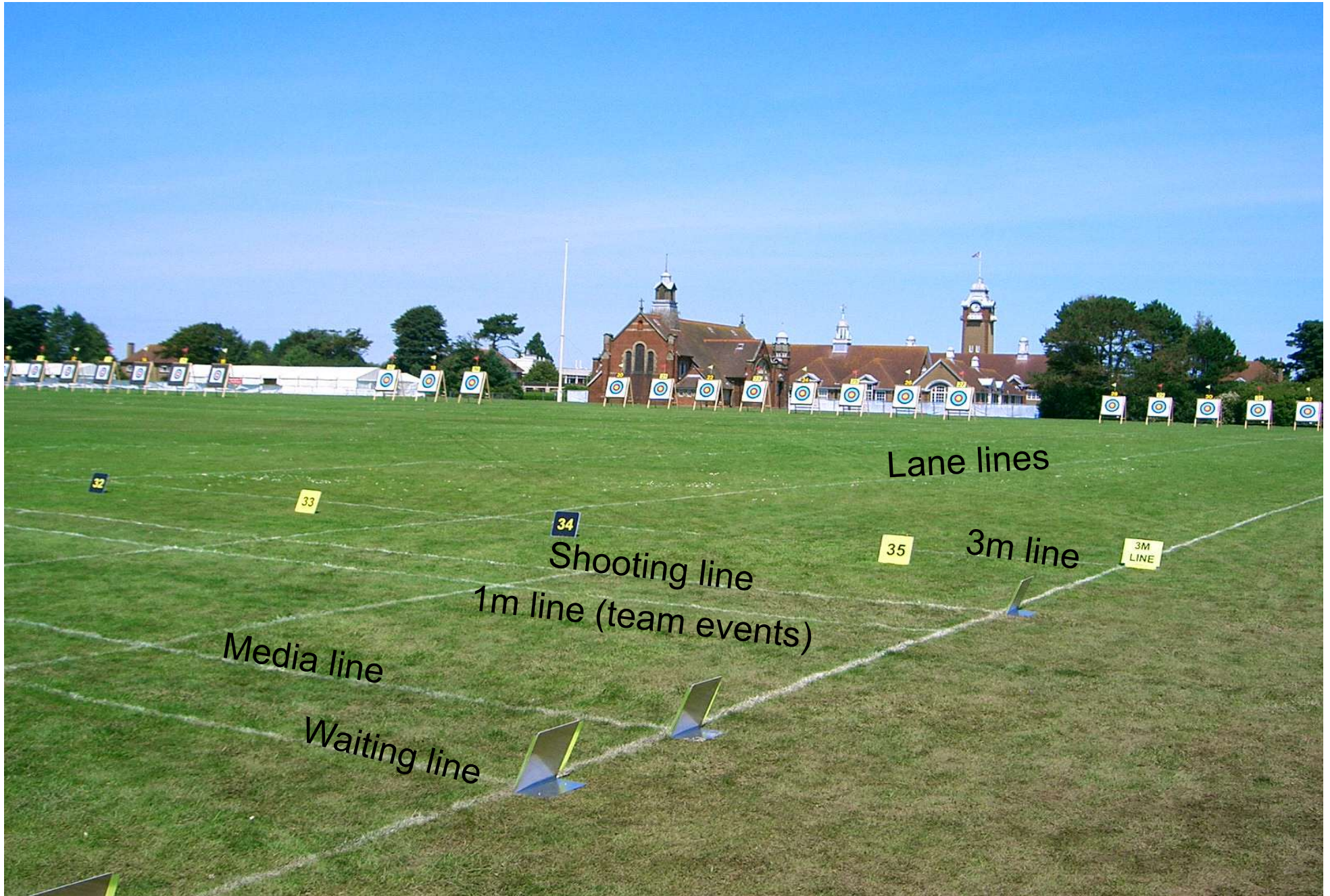

Lane lines

34
Shooting line

1m line (team events)

35
3m line

3M
LINE

Media line

Waiting line



Chapter 4 – Target Checking

What to look for at the Target

- Is it secured/tied down – make sure the bosses are secured with pegs and ropes so they can withstand the weather and archers pulling out the arrows.
- Angle is correct – the angle of the boss should be between 10 and 15 degrees.
- The face fits – there should be enough non scoring area (petticoat) on the boss so an arrow just missing the scoring zone will still hit the boss.
- Centre height is right – the centre of the boss should always be at 130cm (+ or – 5cm).
- Flag is correct size and shape – they should be no more than 30cm and no less than 25cm in length in any direction, be of an easily visible colour and be 40cm above the boss or target number (if on top of the boss). You should also make sure that it does not overhang the boss at all. They are optional in Archery GB.
- Target numbers – they should be clearly visible. World Archery says the numbers should be 30cm tall Outdoors and a minimum of 15cm tall Indoors. They can be placed on the ground in front of the target or on top of the target.
- Line of Golds – at all times the line of the golds must look level.

What to look for at the Target

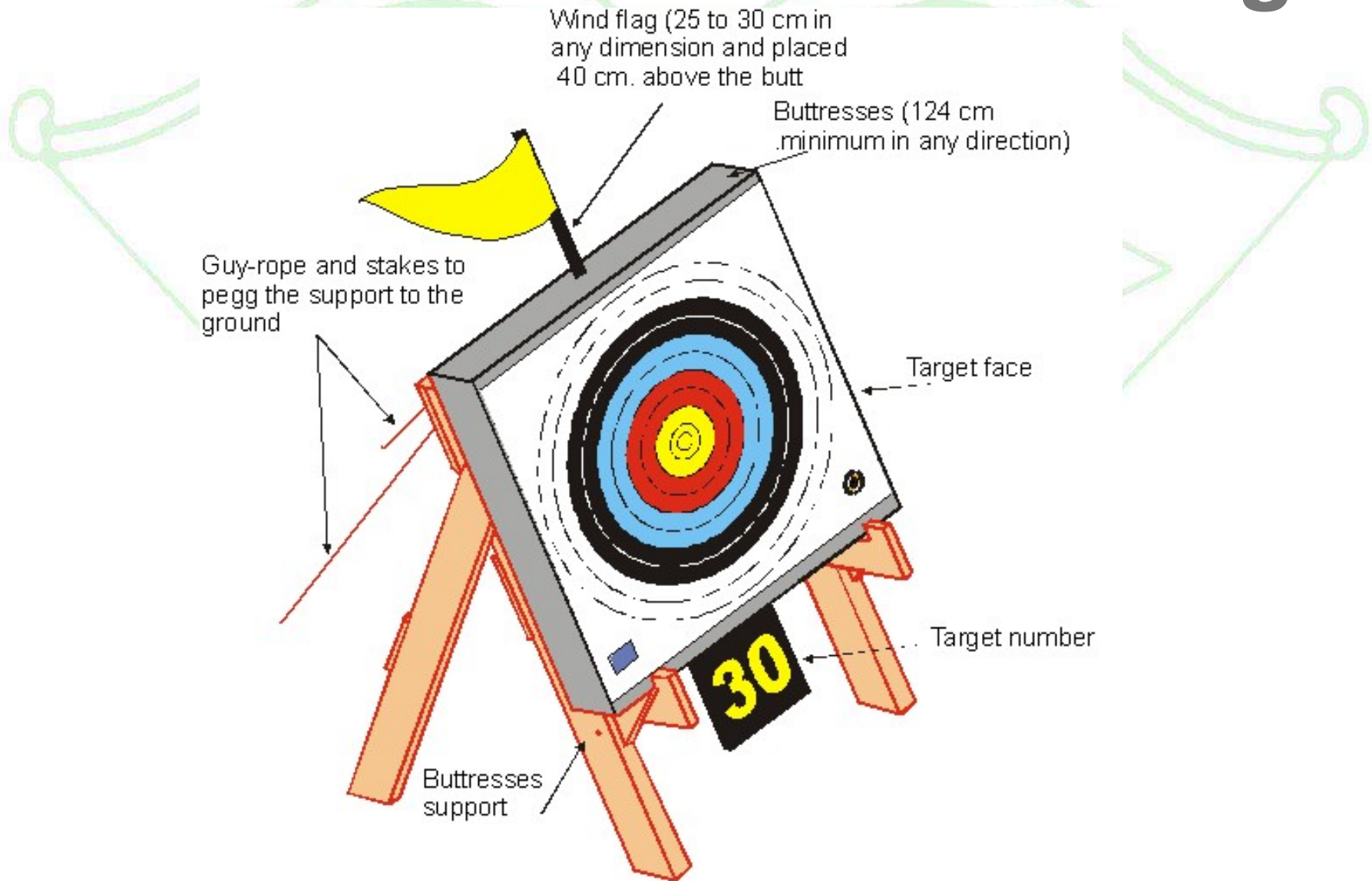

What to look for at the Target

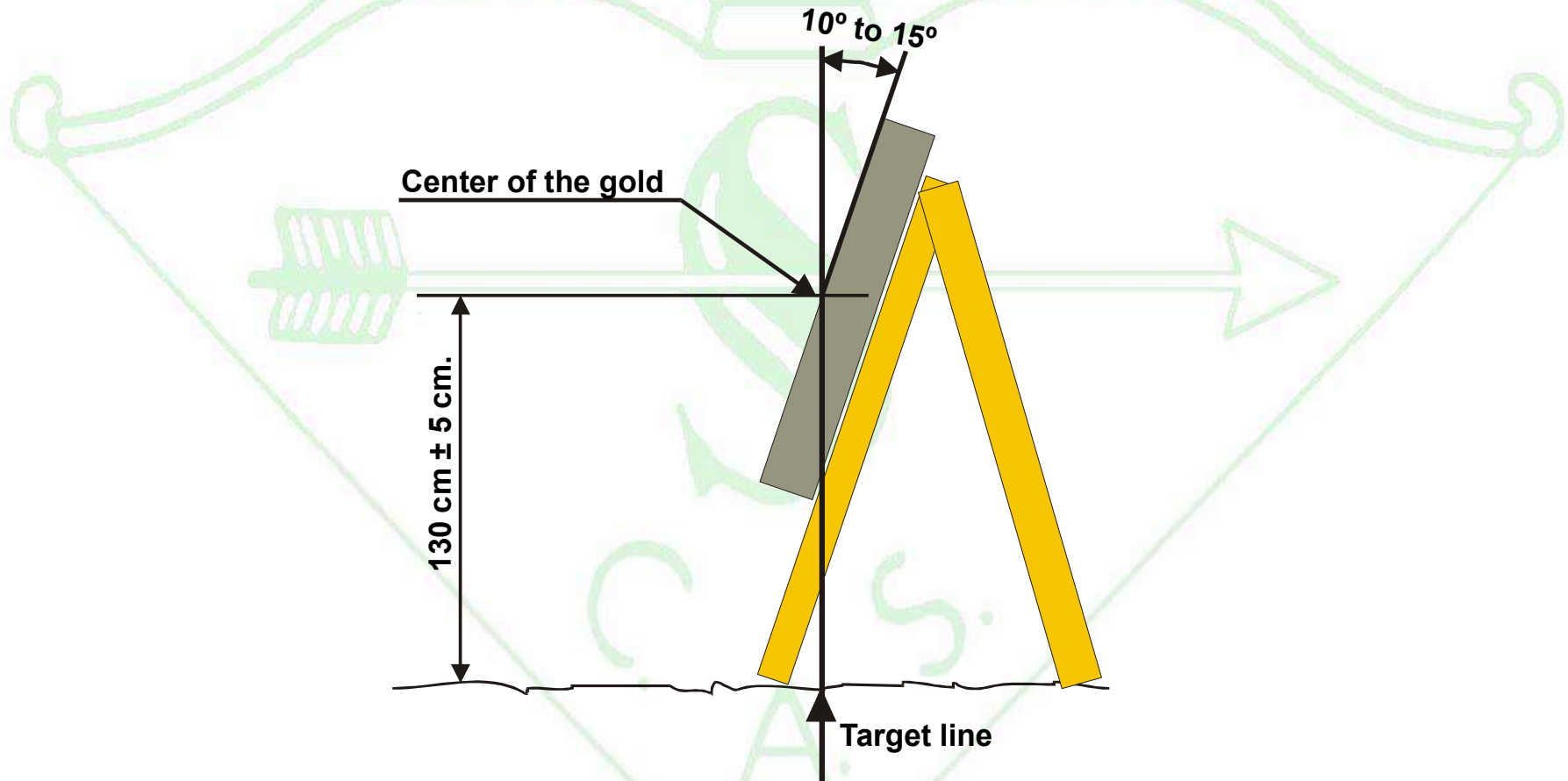

How to check a Target Face

- Always check Target Faces when they are flat and not when they are on the boss.
- Select 1% to 2% of the total number of faces at the tournament to check. If more than one size of face is being used, select some of each size. Select the faces from various places in the roll or stake of faces.
- Check that all the faces are from the same manufacturer and from the same batch. Then check the colours are the same across faces of the same size. If there are differences in manufacturer and / or colour, try to split them up so for example one lot is used on day one and the other lot on day two, or one lot on the Gents Line and one lot on the Ladies Line.
- Check that if the shoot is Record Status, World Record Status, World Archery Star or Rose Award that the faces have a World Archery Licence Stamp. Bjorn is no longer licenced
- Then measure the face to make sure all the measurements are within tolerance.

The Target Face

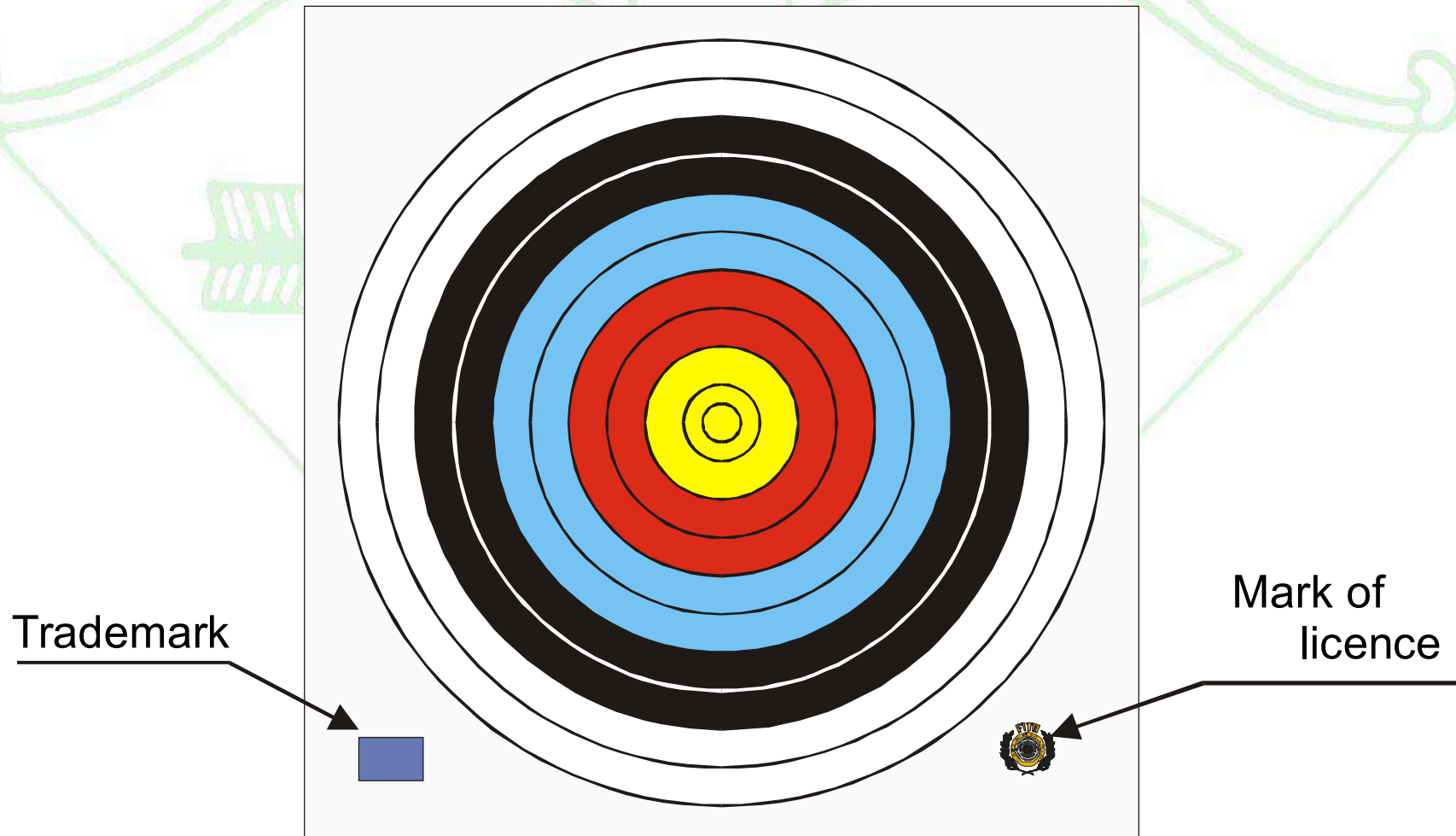

For shoots with Record Status, World Archery Star, WRS or Rose awards, the World Archery licence must be present.

Tolerances – Outdoor faces

Zone	Diameter Of Face		Tolerance in mm
	122	80	
Inner 10	6.1	4	1
10	12.2	8	1
9	24.4	16	1
8	36.6	24	1
7	48.8	32	2
6	61	40	2
5	73.2	48	2
4	85.4	56	2
3	97.6	64	2
2	109.8	72	2
1	122	80	2

(If faces were manufactured before 2007 the tolerance on zones 7 to 1 is 3mm. From Oct 2021 the tolerances are the same for WA and AGB)

Tolerances – Indoor faces

Zone	Diameter Of Face		Tolerance in mm
	60	40	
Inner 10	3	2	1
10	6	4	1
9	12	8	1
8	18	12	1
7	24	16	2
6	30	20	2
5	36	24	2
4	42	28	2
3	48	32	2
2	54	36	2
1	60	40	2

(If faces were manufactured before 2007 the tolerance on zones 8 to 1 is 3mm. From Oct 2021 the tolerances are the same for WA and AGB)

80cm Centre Multiple Face Set up

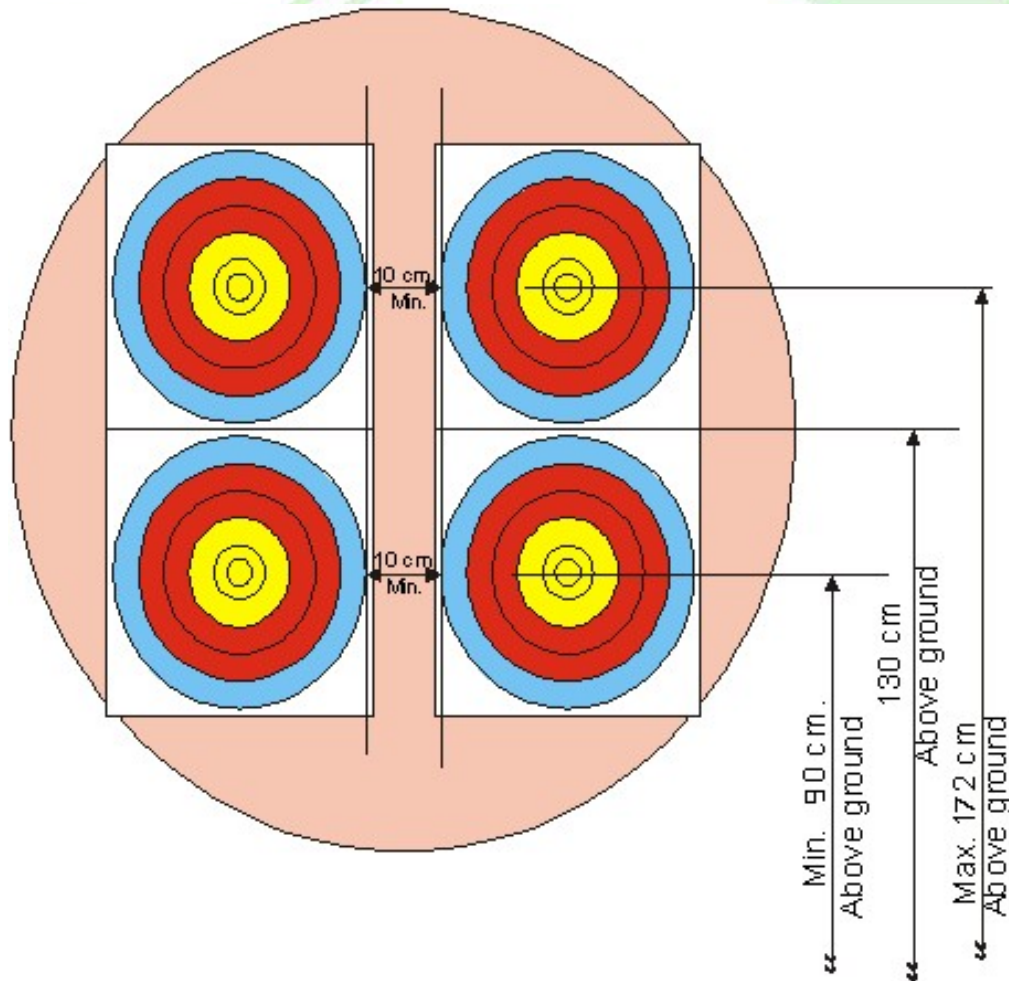

- The 80 cm face can either contain zones 10 – 6, which is used for the 30m distance in a WA Star Or contain zones 10 – 5, which is used in the 50m Qualifying Round and the Compound Head to Head
- The 80cm face can also be set up using 3 faces – where there will be one face on top with the centre at a maximum of 172cm and the two faces on the bottom with the centres at a minimum of 90 cm
- You can also have two 80cm faces per boss – where the faces are a minimum of 2cm apart and the centres at 130cm
- A single 80cm can also be used, with the face on the centre of the boss with the centre at 130cm

These setups can be used for the 30m of a World Archery or in the World Archery 50m Round and Head to Head for Compounds

Multiple Faces

Triangular

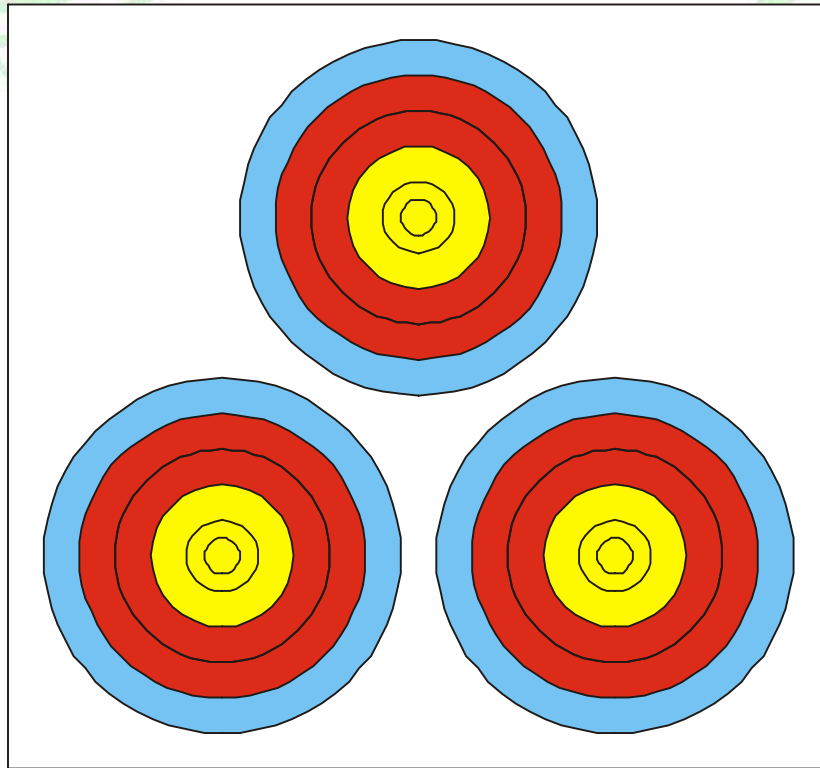

Vertical

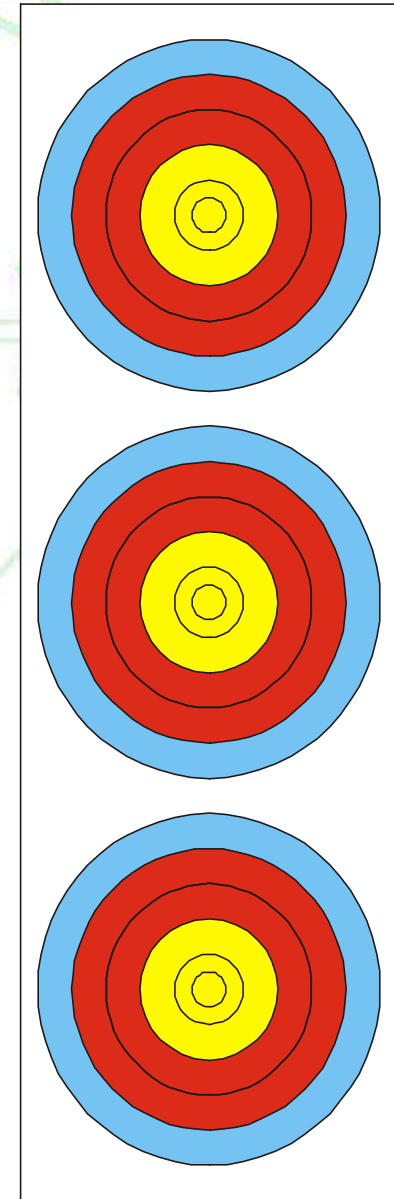

Distance between centres:
22 cm. for 40 cm. target face
32 cm. for 60 cm. target face

Triangular Centre Face Set up (Indoors)

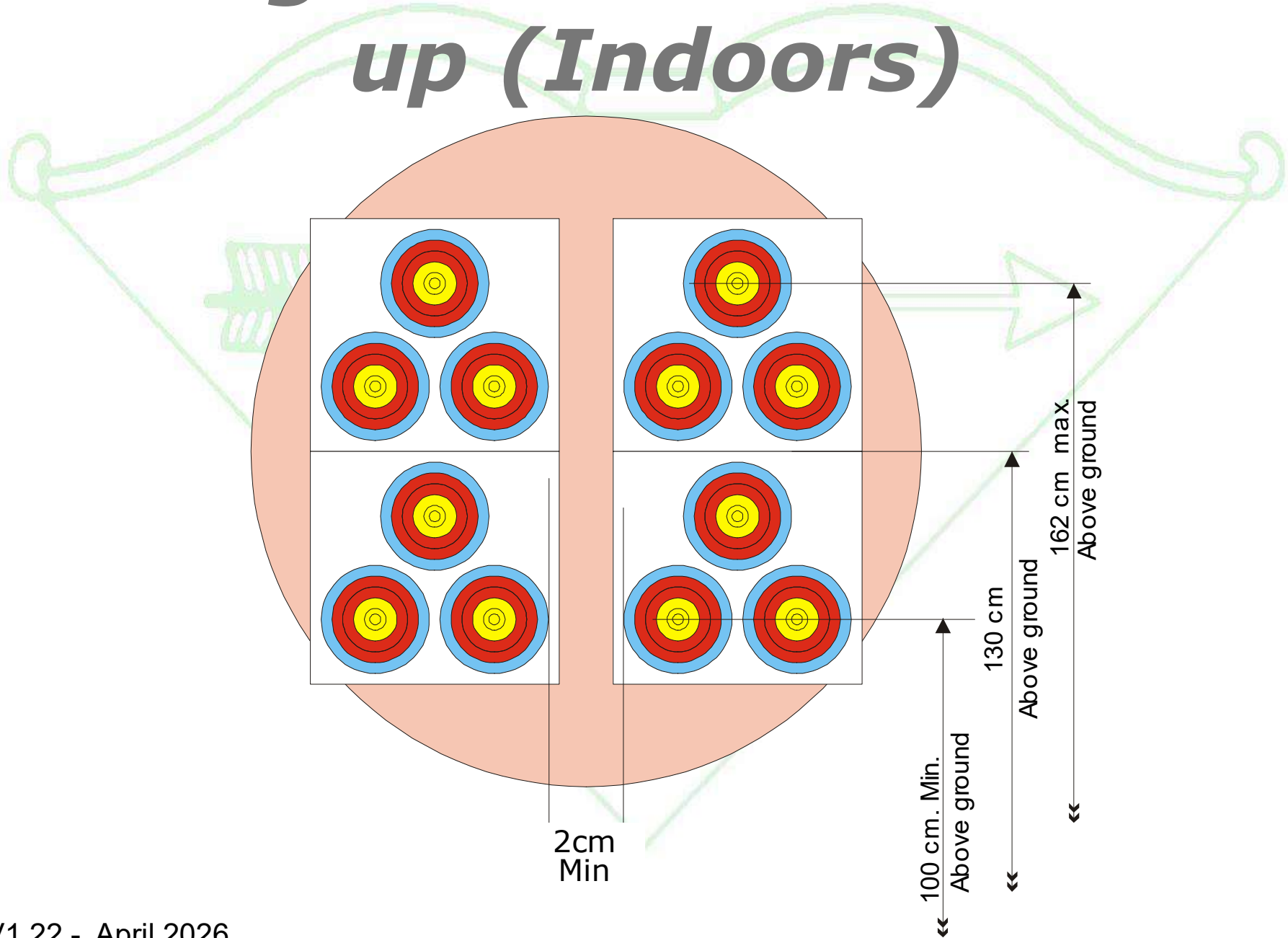

Vertical Centre Face Set up (Indoors)

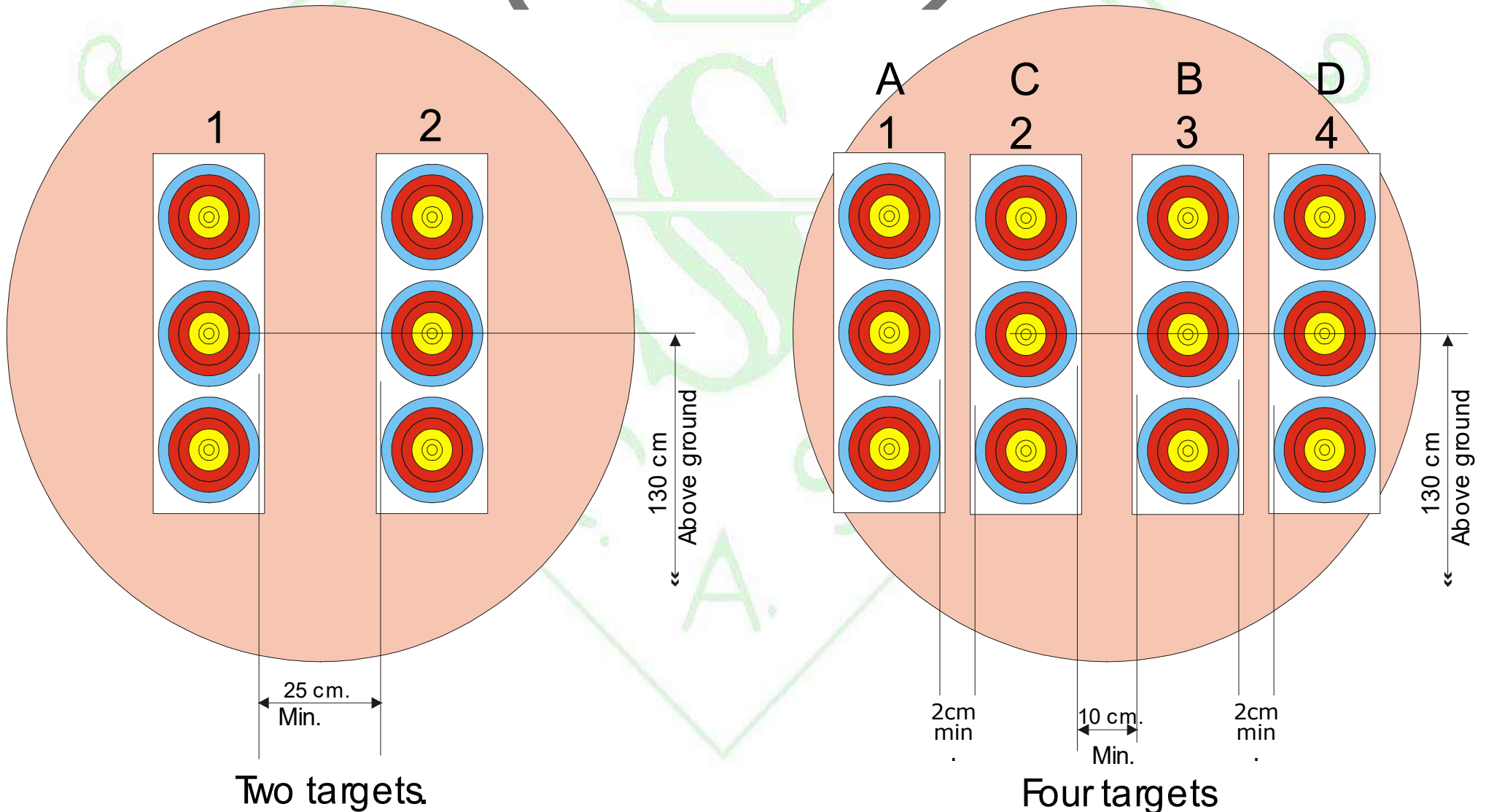

What if you find a problem

- If you do find a problem with the bosses or the faces first of all speak to the Chief Judge and the Tournament Organiser. Most problems can be resolved.
- If there is a problem with the boss or the stand for example, ask the Organiser if there are any spares. If the bosses are too soft get additional packing for them or try and change the bosses rounds so the juniors and ladies are using the softer bosses.
- If the ground is uneven so the golds do not look level, do your best to make them look level.
- If the faces are the wrong size, detail the problems, the manufacturer and the batch number so they can be fed back to the supplier and manufacturer. Inform the Organiser and the archers and if applicable record it on the Record Status Report.

What if you find a problem

- If things are missing such as flags, target numbers or lines on the ground, decide if these things are vital to a competition. For flags and target numbers if it is a Record Status or above status shoot then they should be there, but if there are none available, explain it to the archers, record it on the Record Status Report and advise the Organiser that they will have to get some for the next shoot. If lines are missing, which lines are they – all you really need is the Shooting line, 3m line (for Record Status and above status shoots) and Target line. All other lines can be imagined. Again explain it to the archers, record it on the Record Status Report if needed and tell the Organiser that they will need to have them for the next shoot.
- Normally the only reason to call off a shoot is if there is a safety problem, this is a last step and should be discussed with the Organiser and the other Judges. For all other problems, the only possible consequence is that any records that are claimed **may** be disallowed as the shoot was not shot using the rules.
- If you have any doubts speak to the Organiser and don't be afraid to consult other Judges who may be shooting or experienced archers who are shooting whose advice you trust.



Chapter 5 – Checking Equipment

Equipment Inspection

- Equipment Inspection must be done formally at all Record Status and as a minimum compound bow weights should be checked at Non Record Status Tournaments (including Target, Field, Indoor and Clout).
- Ideally this should be done before the tournament starts, but if time does not permit this then it may be carried on during sighters/practice and the competition, but care should be taken not to interrupt the archers shooting.
- When checking the compound weight it is best to use the same scales for all bows in the same division for consistency.

Different Bow styles

Different types of bows are:

- Recurve
- Compound Unlimited
- Standard
- Longbow
- Barebow
- Asiatic and AFB
- World Archery 3D and Field also have some more divisions, such as Traditional and American Flat Bow

Checking a Bow

- You should always be looking at people's equipment to make sure it conforms to the rules, even if you do not formally check it.
- If you have any suspicions or questions on a person's equipment you can request to inspect it at any time.
- If you see something unusual on someone's bow do not be afraid to ask them what it is and what it does, although it is best to ask them during a break so as not to disturb their shooting.
- At Record Status events there is a formal inspection before the event
- It is always the archer's responsibility to make sure their equipment is okay, if they have any questions they should ask.

Checking a Bow

- When checking a bow always try to avoid touching the bow, if you have to hold the bow do so by the limbs in the area closest to the riser, with the string facing you. Never touch the grip.
- The first thing to do is check the overall appearance of the bow. Check for anything unusual or different and for any signs of wear and tear.

Checking a Bow



- All Compound bows have a maximum weight of 60lbs. To check the weight of a Compound
 - Pass the scale to the archer and ask them to attach it to their string / D Loop. Advise them to make sure it is attached securely.
 - If they wish to put an arrow on their bow they can
 - Ask them to draw up their bow in the normal way facing the targets. Advise them to be careful the scales do not slip and to be careful of people walking by.
 - Make sure the archer does not twist their wrist or pull back the scales unevenly as this can lead to false readings. Also be careful that the scales do not catch on their clothes.

Checking a Bow



- The following are **never** permitted
 - Any electronic communication device and head-sets in front of the waiting line.
 - Any electronic or electric device on the shooting equipment.

Recurve Bow

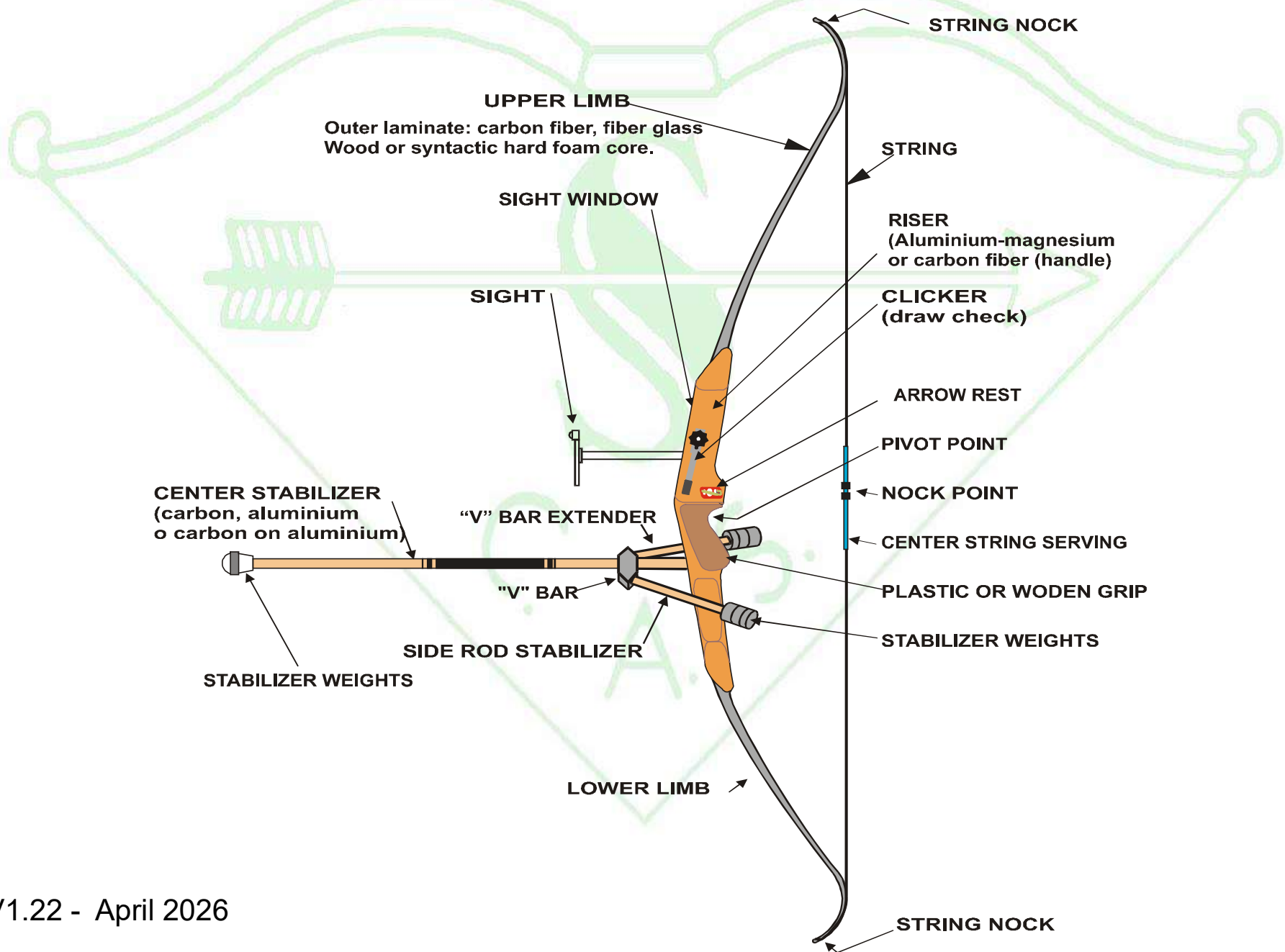

Recurve Bow – Handle/Riser

- The riser must not be the shoot-through type; it can have a bracer provided that it doesn't consistently touch the archer's hand or wrist.
- The riser can be painted with a multi-coloured style.
- Risers can be made of any material.
- The bow can have the riser in the monoblock system, or it can have separate limbs.



Recurve Bow – Handle/Riser

- Arrow Rest - Can be adjustable.
- Pressure Point – Can be fixed or adjustable/
- Clicker / Draw Check Device - cannot be electric or electronic.
Can only have one device, but it can give more than one signal for draw check.

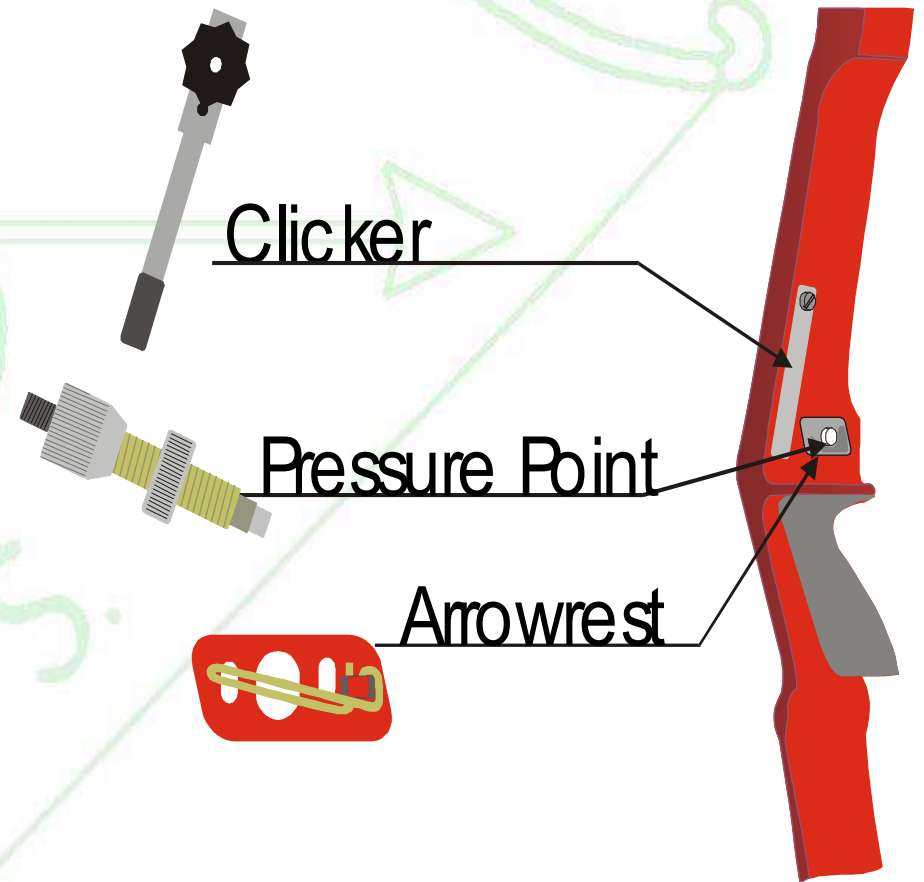

Recurve Bow – Handle/Riser

- Pressure Point –
Can be placed no
further than 4 cm back
from the pivot point of
the bow.

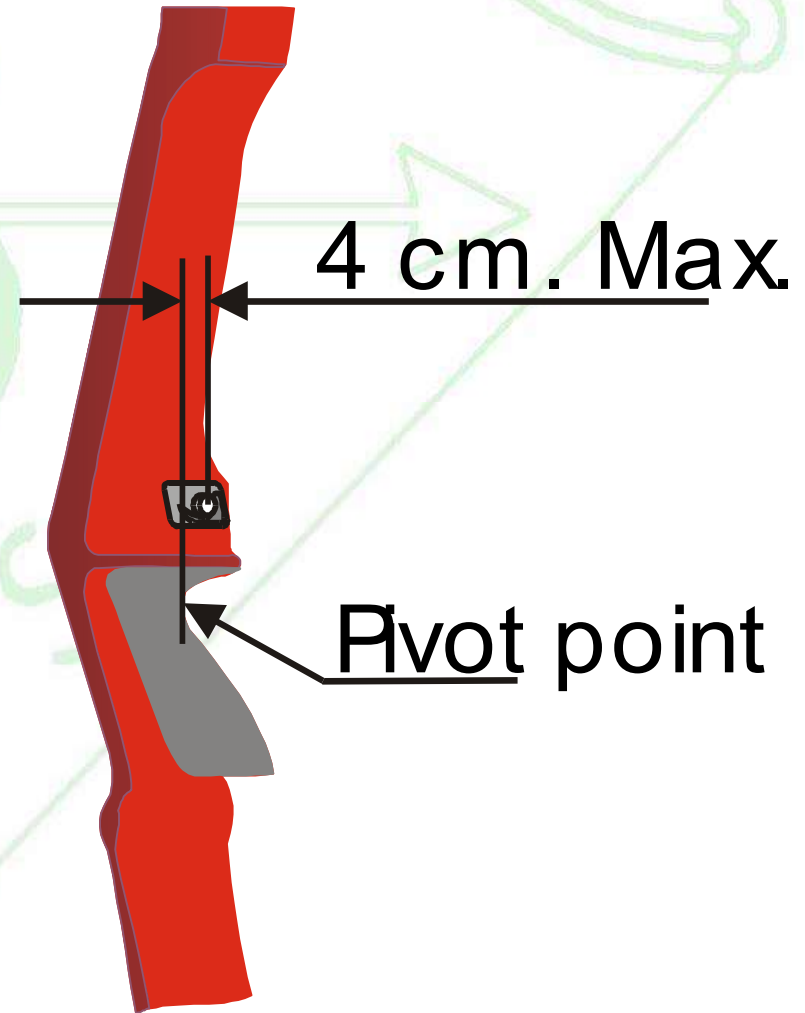

Recurve Bow – Limbs

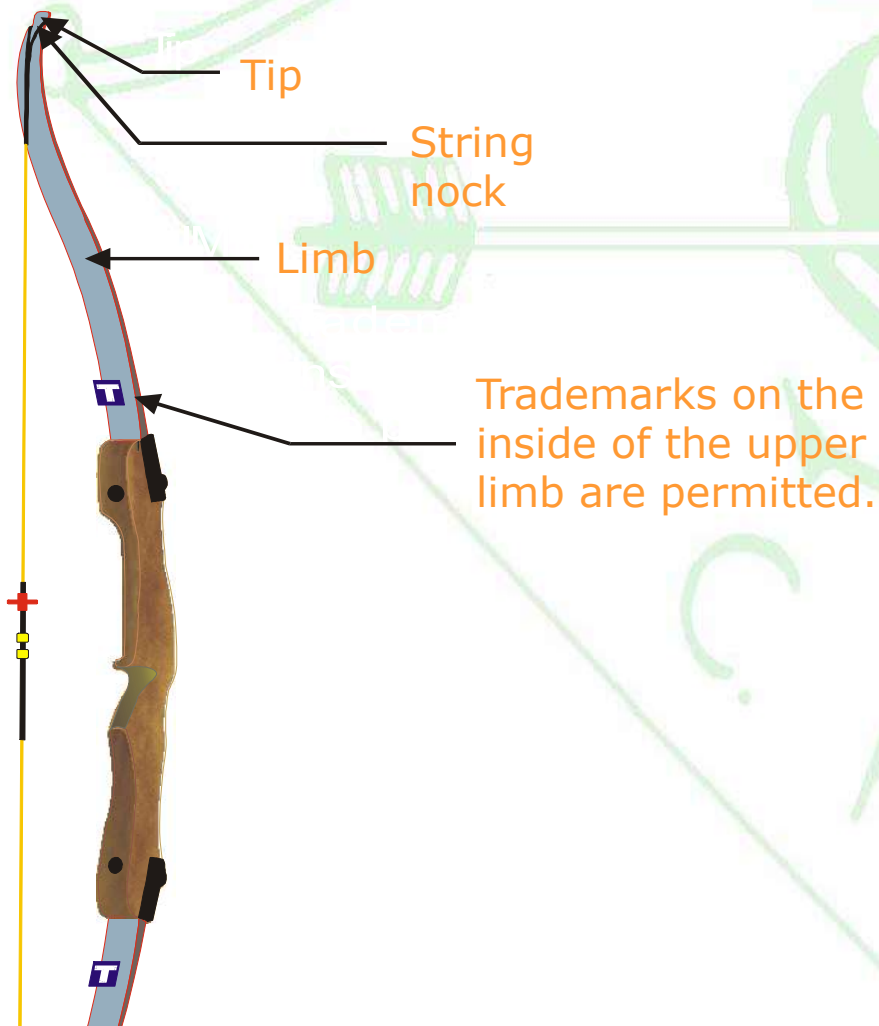

- Limb savers are permitted on both upper and lower limbs.

Recurve Bow – String

- The string may be made of any number of strands, which may be of different colours and of any material.
- In-line string silencers are not allowed.
- The centre serving of the string must not end within the archer's vision at full draw.
- The string must not in any way assist aiming through the use of a peephole, marking or any other means.
- Check the string does not look frayed or worn and that it is securely attached to the tips and in the grooves at the top of the limbs.

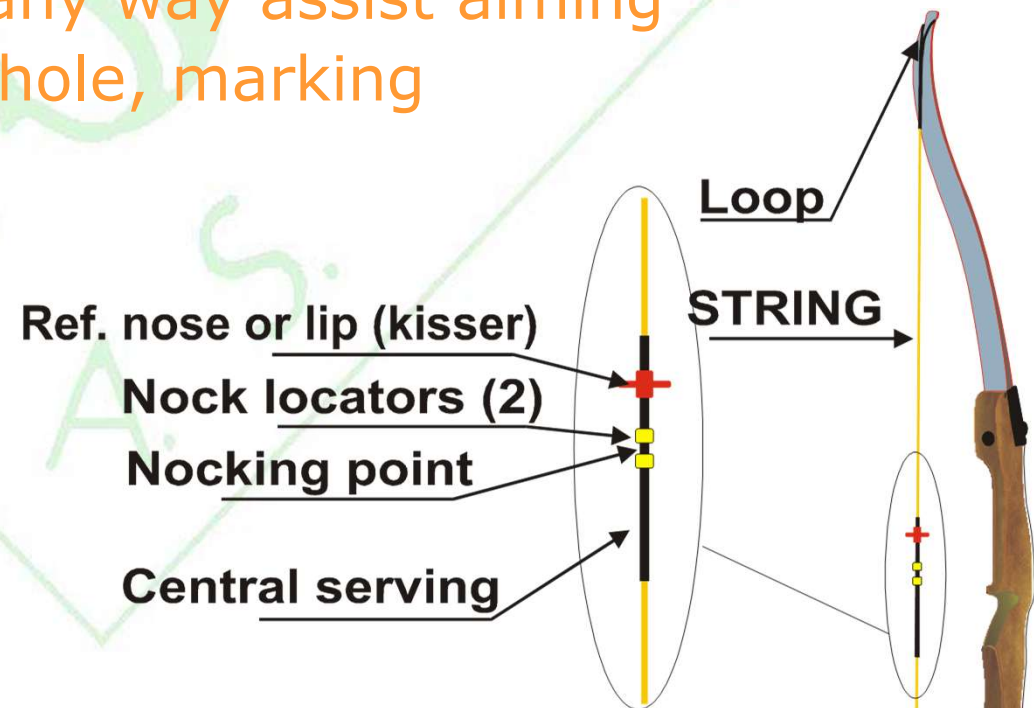

Recurve Bow – Sight

SIGHT PINS

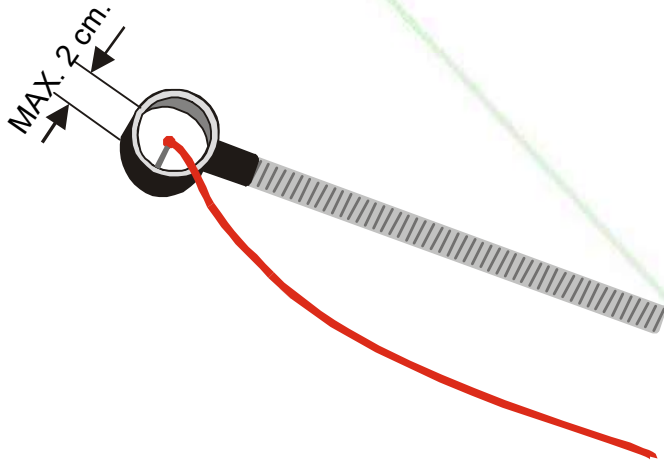

Vertical guide with
distance scale

Charriot

Windage adjustment

Distance adjustment

Sight

Extension

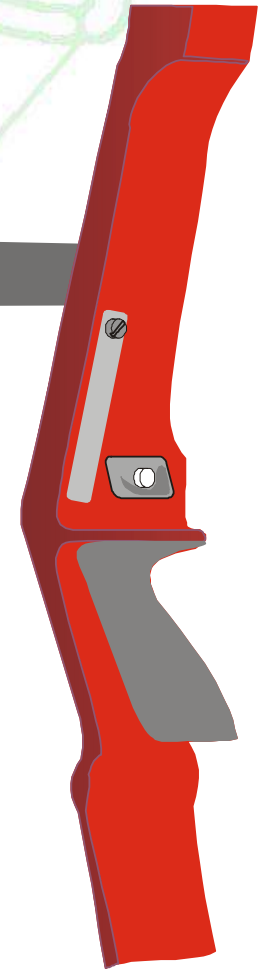

Recurve Bow – Sight

- The sight must not incorporate optic devices such as lenses, prisms, etc.
- Electric or electronic devices are not permitted.
- The sight must not offer more than one sighting point and the fibre optic point must not offer more than one illuminated sighting point.
- The overall length of the sight (tunnel / pin / optical pin, etc.) must not exceed 2 cm in the line of vision of the archer.
- The total length of the fibre optic pin can exceed 2 cm, provided it ends outside of the line of vision of the archer. After 2cm the fibre optic pin must bend.

Recurve Bow – Sight

Length tunnel 1 cm, Pin 2 cm, total length 2.5 cm

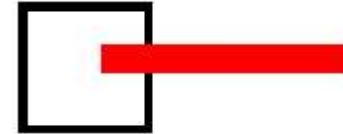

Length tunnel 1 cm, Pin 2 cm, total length 2 cm

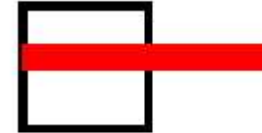

Length Tunnel 2 cm, Length Pin 2 cm, total length 3,5 cm.

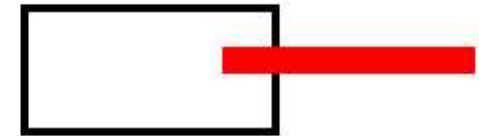

- The Fibre Optic Pin is considered to be a separate unit to the housing supporting the pin.
- The housing and the Fibre Optic Pin should be measured independently and neither can exceed 2cm in the line of vision
- All examples are correct and legal

Recurve Bow – Stabiliser

- These are permitted in any quantity, but they must not:
 - Serve as a string guide.
 - Touch anything but the bow.
 - Represent any obstruction to other archers on the shooting line.

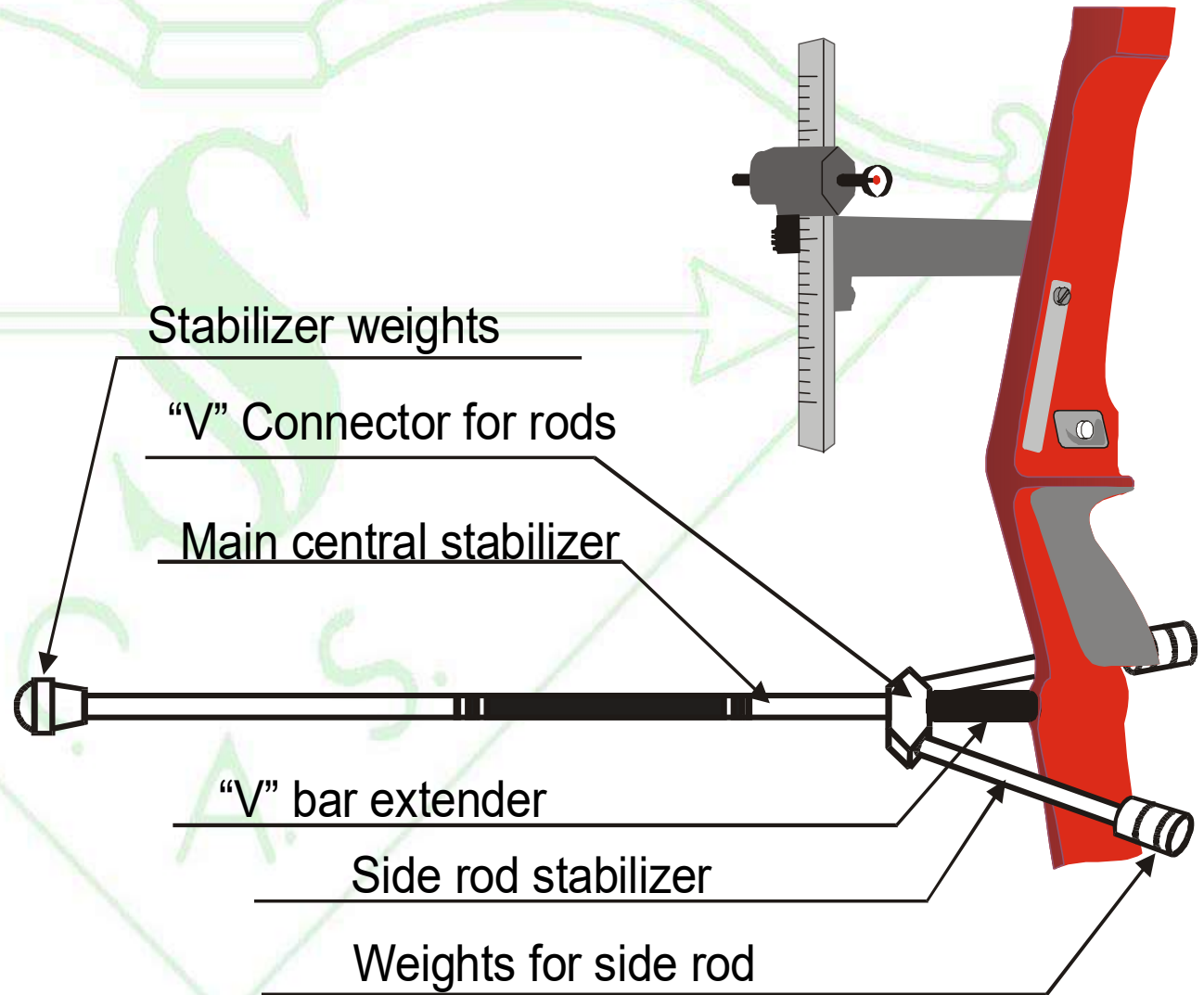

Recurve Bow – Finger Protection

- The finger protection must not incorporate any device that will assist the archer in holding, drawing and releasing the string.
- They may incorporate a finger separator, a platform or anchor plate.

FINGER PROTECTION (TABS)

Basic one part

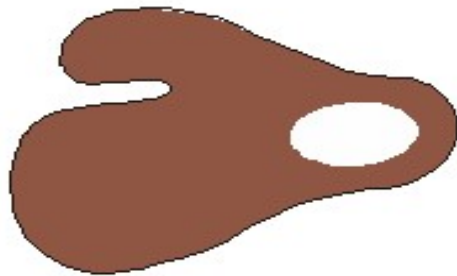

Basic several parts

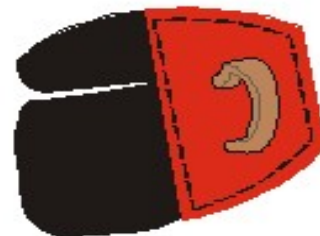

Platform



Compound Bow

- All types of additional devices, unless electric or electronic, are permitted.
- The peak draw weight must not exceed 60 lbs.
- Cable guards are permitted.

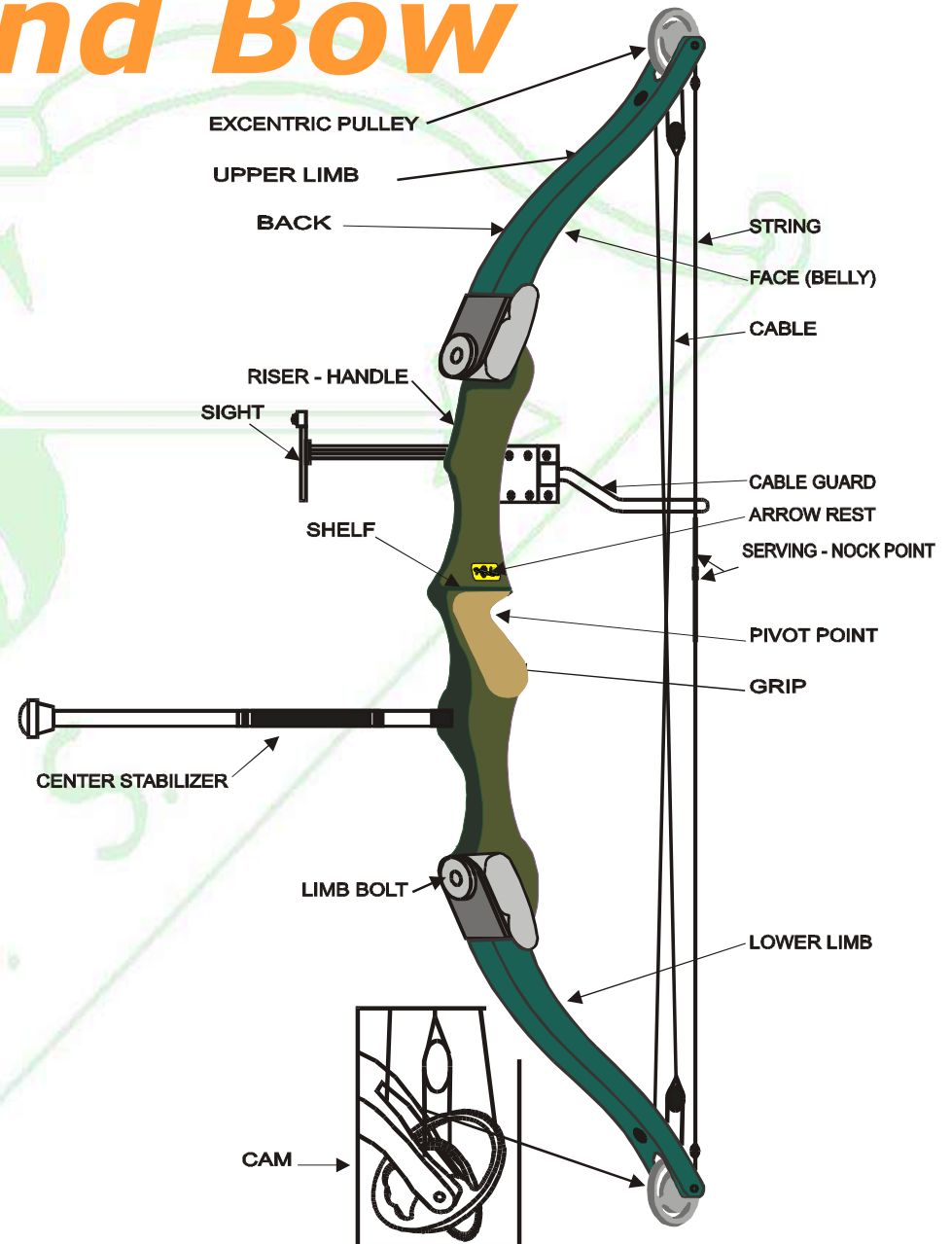

Compound Bow – Handle/Riser

- The riser may be shoot-through.
- It can have a brace or split cables provided they do not consistently touch the archer's hand, wrist and/or bow arm.
- The riser can be painted in multi-colours.

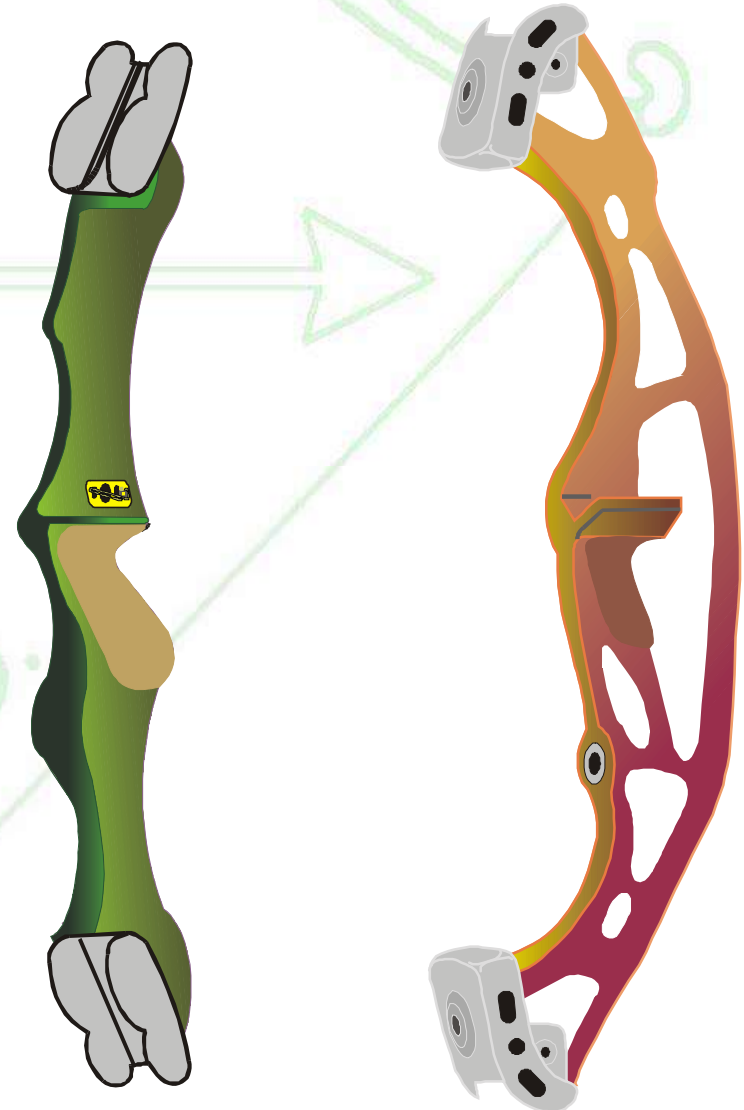

Compound Bow – Handle/Riser

- Arrow Rest – can be adjustable.
- Pressure Point – Can be placed no further than 6 cm back from the pivot point of the bow. Can be fixed or adjustable.
- Clicker / Draw check device - cannot be electric or electronic. No limitation in quantity. Can be audible, tactical or visual

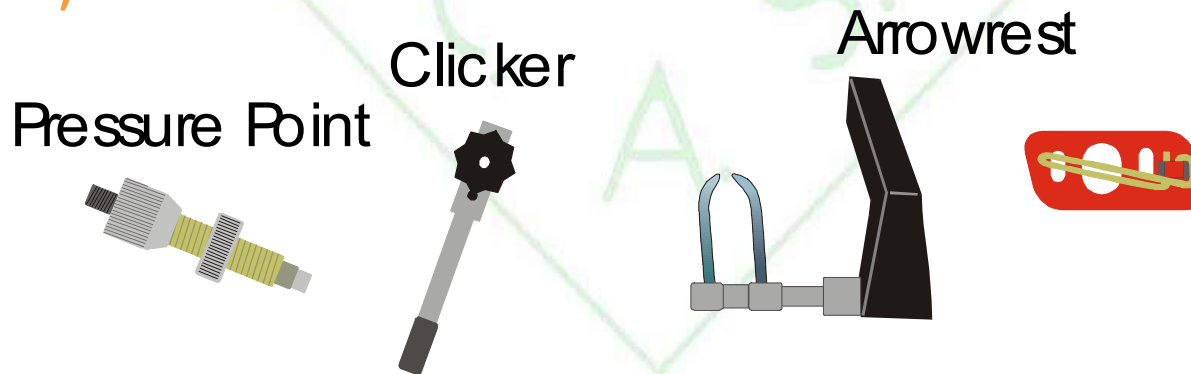
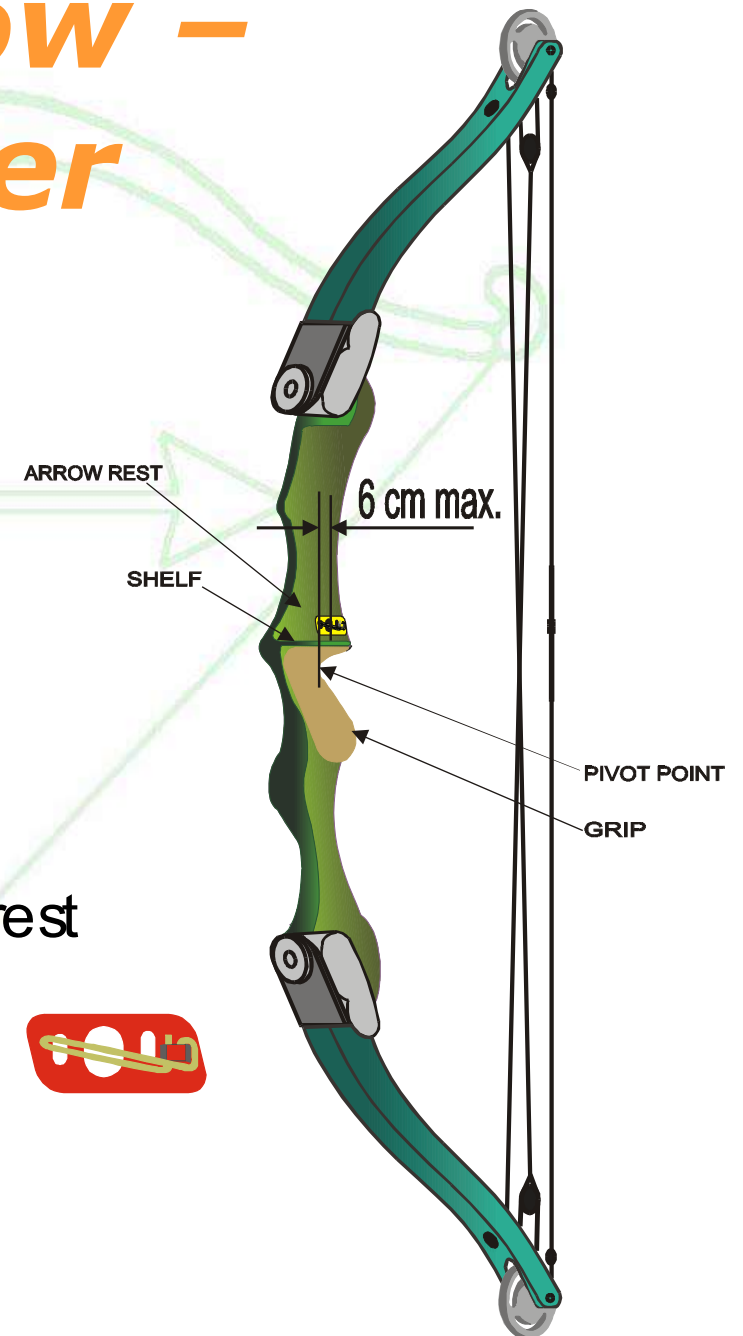

Compound Bow – String

- Check that the string and the cables are securely attached with no wire showing.
- Check the peep – sight is securely held in place so it cannot fall out.
- There are no restrictions to what you can have on the string.

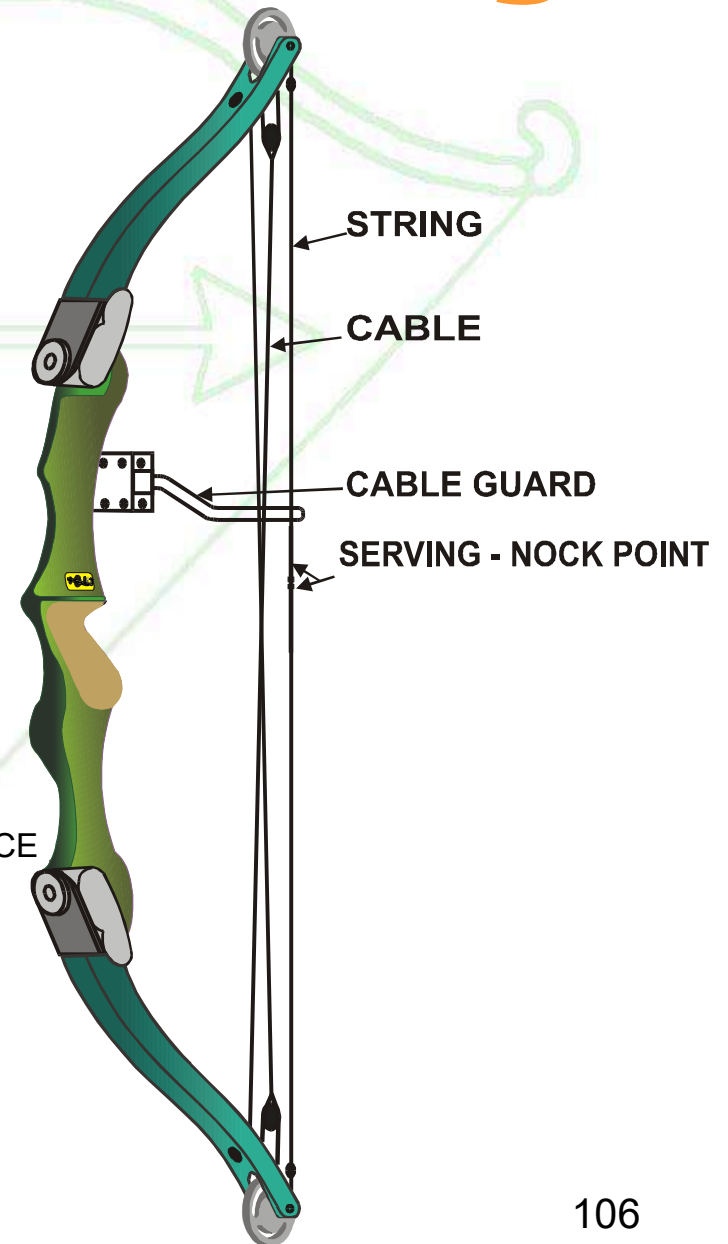

LOOP BOWSTRING



LIP OR NOSE MARK (KISSER)



PEEP HOLE AND HOLD-IN LINE DEVICE



Compound Bow – Sight

- May incorporate optic devices like lenses, prisms, etc.
- Also may incorporate a chemical glow stick provided it does not disturb other archers and provides only one sight point.
- In World Archery Peep Eliminator Sights are allowed
- Electric or electronic devices are not permitted.
- No other restrictions.

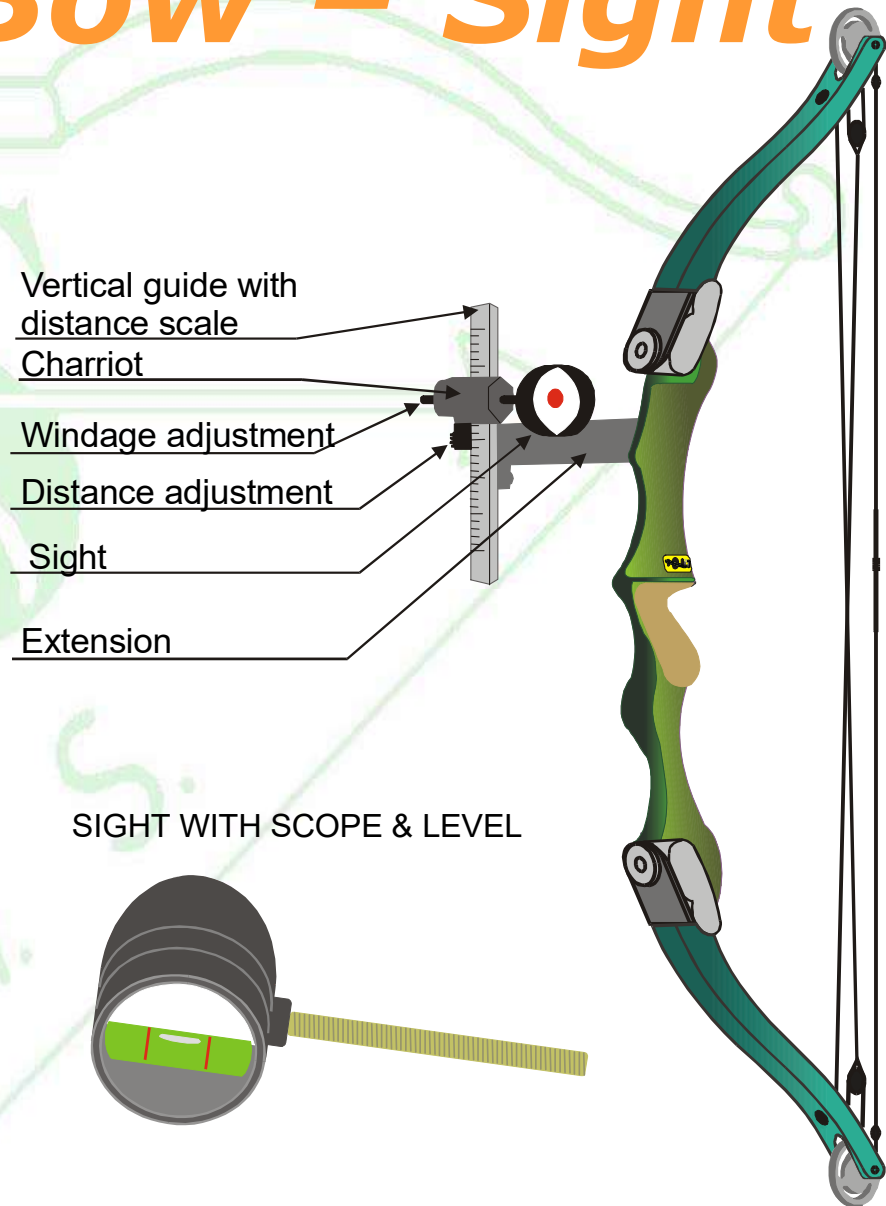

Compound Bow – Stabiliser

- These are permitted in any quantity, but they must not:
 - Serve as a string guide.
 - Touch anything but the bow.
 - Represent any obstruction to other archers on the shooting line.

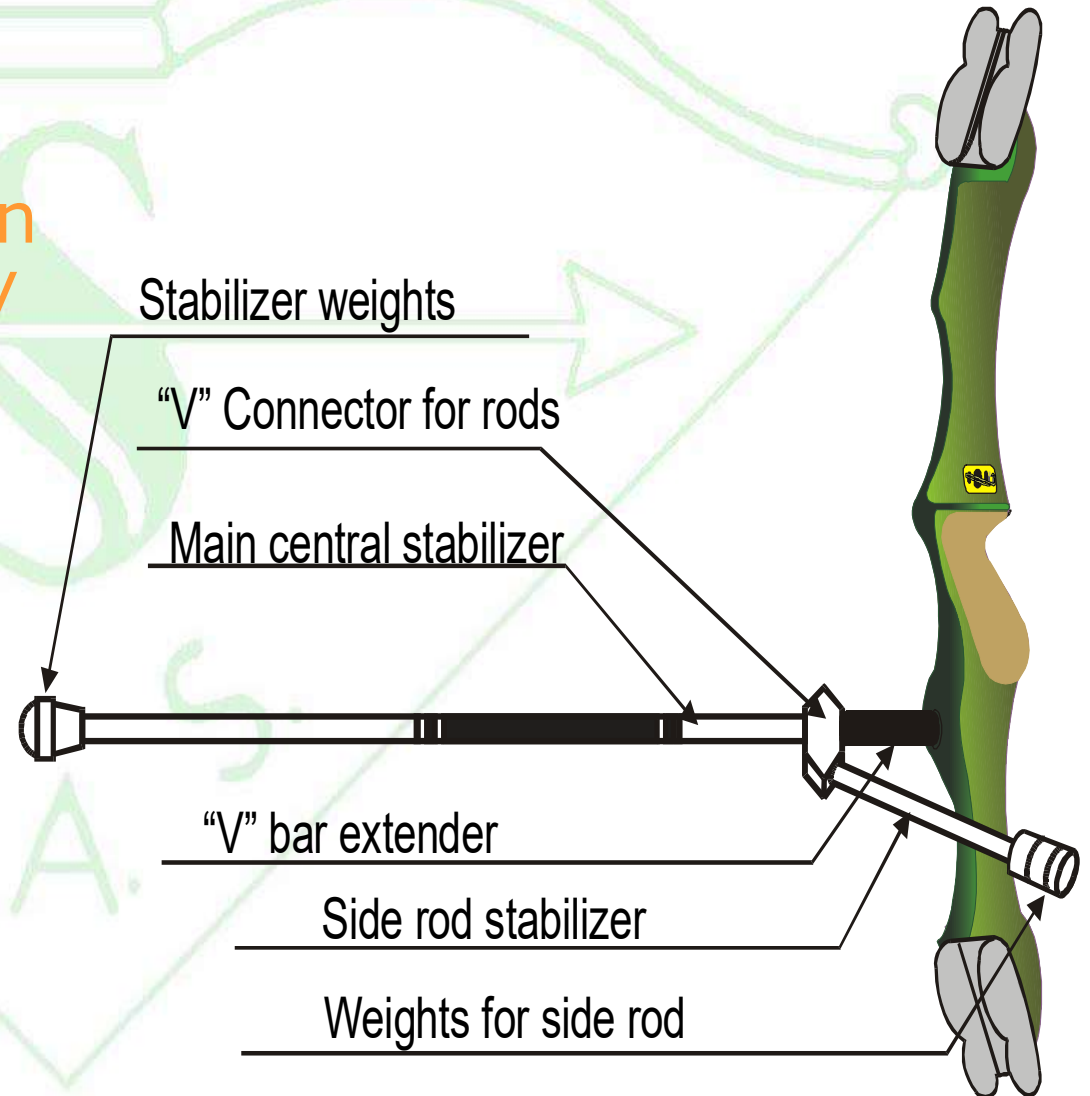

Compound Bow – Finger Protection

- Release Aids must not be attached in any way to the bow.
- They cannot incorporate electric or electronic devices.

FINGER PROTECTION (TABS)

RELEASE AID

Basic one part Platform

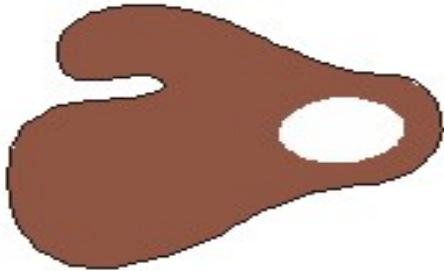

Compound and Recurve Bow – Arrows

- They must not cause undue damage to target faces or bosses.
- Shafts - maximum diameter of 9.3 mm.
- Points / Piles - maximum diameter of 9.4 mm.
- All arrows used at any end must carry the same pattern and colours of fletchings, nocks and crestring, if any.
- All arrow shafts will carry the archers identification marks.
- Arrow wraps cannot be longer than 22cm from the groove of the nock.



Compound and Recurve Bow – Accessories

- The following are allowed
 - Tassels.
 - Foot Markers – Maximum height of 1cm.
 - A tripod for a scope.
 - Wind Indicators (non electric or electronic) on the shooting line.
 - Electronic wind indicators behind the waiting line.

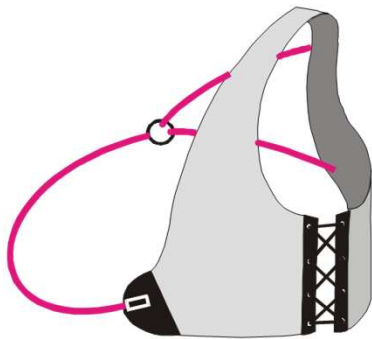

Dress shield



bow sling

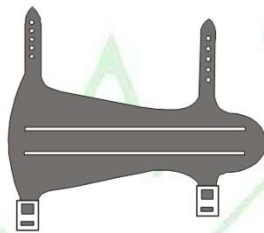

Bracer (arm guard)

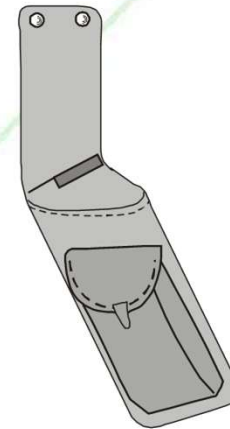

Quiver

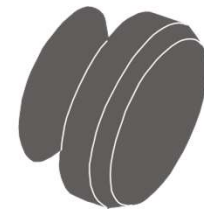

Limb savers

Compound and Recurve Bow – Visual Aids

- Field glasses, binoculars, telescopes and other visual aids may be used for spotting arrows.
- They must not represent any obstruction to other archers on the shooting line.
- Prescription spectacles, shooting spectacles and sunglasses may be used, provided that none of these are fitted with micro-hole lenses, or similar devices, nor may they be marked in any way that can assist in aiming.
- The spectacle glass of the non-sighting eye may be covered with film or tape to obscure vision, or an eye patch may be used.

World Archery Standard Bow

- The World Archery Standard Bow and round are designed for beginners using basic and cheap equipment to promote Archery.
- It is very similar to the Recurve Bow but more basic
 - Wood or metal simple riser, wood or fibreglass limbs.
 - A simple non adjustable arrow rest and pressure button.
 - Simple sight and tab (no platform).
 - Limited accessories and no spotting devices.
 - The unstrung bow with all accessories and sight must pass through a 122mm ring.
- Full details can be found in the World Archery Rule Book.

Barebow

- Barebow has the same equipment as the Recurve Bow, with the following additional provisions and/or modifications.
 - The bow must be bare except for the arrow rest, and free from protrusions, marks, or blemishes or laminated pieces (within the bow window area) which could be of use in aiming. Any markings must be taped over. Multi-coloured risers are permitted

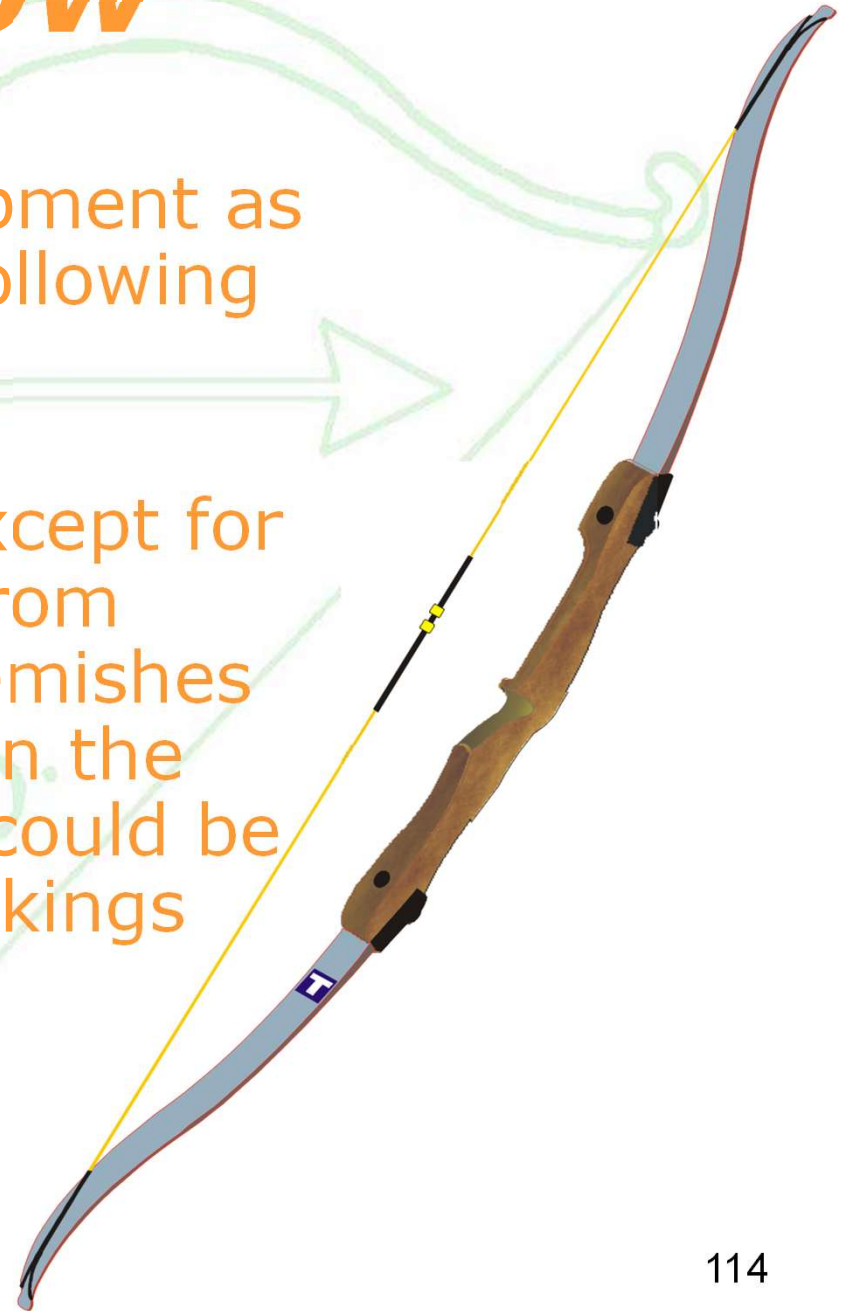

Barebow

- No Lip or Nose Marks (kissers) are allowed on the string.
- In-line string silencers are not allowed.
- No Draw Check Indicators (clickers) are allowed.
- No Bow Sights or aiming devices are allowed.

Barebow

- The bow (braced or unbraced and regardless of the bow's orientation or angle), including any combination of weights, vibration dampeners, and other attachments, must pass through a ring with a diameter of 12.2 cm (+/- 0.5 mm) without moving, flexing or turning the attachments. The attachments must not aid the athlete in aiming or ranging in any way.
- There are some rings with a slot in so the bow does not need to be unstrung

Recurve Traditional – Archery GB Target

- Recurve Traditional is very similar to the Barebow with the following variations
 - Arrow shafts must be made of wood
 - Fletches must be natural feather, but metallic piles and plastic nocks may be used
 - Archers must adhere to one anchor point and one finger position throughout a tournament

Longbow



- The definition of Longbow differs widely between Archery GB and World Archery Field. World Archery Target Archery does not recognise the Longbow.
- Please refer to the World Archery Field Rule Book for the details.
- World Archery Field also has Traditional Bows which is a combination of Barebow and Longbow World Archery Rules.

Longbow



- Bow

- Must be a traditional Longbow made of wood, either 'self', 'backed' or 'laminated' with cambered (stacked) belly and horn nocks
- Unless a 'self' bow, the limbs will be a simple single curve from the handle to nock when at full draw
- If the arrow is less than 27 inches long, then the bow must not be less than 5 foot long. If the arrow is 27 inches long or more, then the bow must not be less than 5 foot and 6 inches long. This is measured along the back between the string nocks
- The depth (from the back to the belly) of the bow must not be less than $\frac{5}{8}$ (five eighths) of the width of the bow in the same section
- The bow may be made of bamboo
- There will be no support for the arrow on the bow

Longbow

- The string can be either natural or man-made. It can have a 'kisser' if wanted to aid a consistent draw position, but for no other purpose
- In-line string silencers are not allowed.
- Sights, as such, are not allowed, except for
 - Marks on the bow limb
 - A rubber band on the limb, but no more than 1/8" in thickness
 - An artificial point on the ground, but no more than 6" in height or 3" in diameter and not impede other archers
- Arrows must be made of wood with feather fletches and have either horn-reinforced, self or applied nocks. The piles must not exceed the diameter of the shaft where they meet. Arrows should be marked so they can be claimed easily
- Hand Protection
 - Finger stalls, finger tips, gloves, tab or tape can be used as long as they do not assist with the drawing, holding or releasing the string
 - A separator on the tab or a platform tab can be used. Although no form of extension to provide a greater angle prior to release can be used
 - A glove, mitten or similar can be worn on the bow hand as long as it is not attached to the grip



Chapter 6 – Judge Duties

Before a Tournament

- Your Judging duties start the day before a tournament. You need to make sure :-
 - You need to make sure you know what time the shoot is supposed to start – you need to arrive there 1 hour before the assembly or practice, which ever is earlier.
 - Make sure you know how to get to the tournament. Most organisers are more than happy to provide a map if asked.
 - Check the weather forecasts and make sure you have appropriate clothing with you for all weathers.
 - If you are not sure about the catering arrangements at the shoot make sure you have plenty to eat and drink.
 - Check your Judging equipment to make sure everything you will need is there and is in working order.
 - Read the Rules relating to the rounds being shot and make notes on them so you are prepared.

When you arrive at a Tournament

- When you arrive at a tournament you need to firstly find the Chief Judge and the Tournament Organiser and introduce yourself.
- Be ready and eager to start checking the field but wait for the Chief Judge to allocate your tasks.
- Whilst it is important to check the field as soon as possible you need to do it whilst there are some archers about so they can see you doing it. Also you can't check the field until it is actually ready.
- When the field has been checked make sure the Organiser / Field Party are told of any problems or if everything is okay.
- If the Tournament is Record Status or World Record Status then all archers equipment must be checked.

When you arrive at a Tournament

- Make sure that you show your AGB Membership Card to the Chair of Judges (if you are the Chair of Judges show another Judge).
- Check that the Venue has a Range Registration Certificate. You still need to check the venue thoroughly. If they do not have a Certificate inform them that they need to arrange one and they can contact AGB for more information.
- Don't be afraid to ask questions of the Organiser and the other Judges. Chat to people and to archers and try to relax.

Assembly / Speeches

- Assembly is the chance for the Judges to be introduced to the archers and instruct them on the conduct of shooting. During assembly you should always try to look smart and attentive.
- Sooner or later you will have to do the address at assembly. This is something that a lot of new Judges struggle with but don't worry it gets easier with time and practice, you just have to grit your teeth and get it over with.

Assembly / Speeches

- Some tips are :-
 - Make sure you have notes to read from.
 - Ask someone else to read your notes through to make sure you have everything.
 - Tailor your speech to the audience, if it is a club or beginners tournament you may want to go into more detail.
 - Speak loudly and clearly and remember to breathe.
 - Try to keep things light rather than a series of orders to the archers.
 - Don't panic if you forget something, most Judges will whisper to you if you have forgotten something so you can add it in at the end.

Assembly / Speeches

- Things to try to include are :-
 - Start by saying Hello and then say 'Today we are shooting ? Rounds to World Archery/Archery GB Rules'.
 - How many ends of sighters / practice are there.
 - How are they scoring – 5 zone or 10 zone scoring, if indoors remind them that compounds use the Inner 10 and there are no Xs.
 - If a World Archery Round remind them to mark the arrow holes.
 - Remind them if they have a problem either writing down the arrow values or deciding the value of an arrow to call a Judge.
 - Remind them that if they have a bouncer or an equipment failure to let a Judge know.

Assembly / Speeches

- Is there anything else to tell them that is tournament specific, for example if they need to be careful of ropes on the grounds.
- Remind that all mobile phones need to be off or on silent and this includes the archers and their guests.
- Always finish it by saying 'If anyone has any questions please just ask one of us. And we will start sighters / practice / the tournament in ? minutes'.
- Other announcements that need to be made are :-

Assembly / Speeches

- Change of distance – Generally the announcement will be – ‘Archers, any assistance you can give in moving the targets to the next distance would be greatly appreciated. Please be ready to restart shooting at x’.
 - Always check with the Organiser / Field Party how long they want to move the targets. Remember to add about 5 minutes on to that figure for the archers to score the arrows and give any archers who are in the Field Party a chance for a rest.
 - Check there is nothing else the Organiser wants announcing at the same time, such as catering arrangements or the raffle.
 - Round the restart time up to a easier figure, for example if you have calculated the restart time as 2.56, round it up to 3pm.
 - As the archers are now spread along the line you may need to do the announcement twice, once at each end to make sure all the archers hear, this depends on the length of the line and how powerful your voice is.

Assembly / Speeches

- Reminder of restart – Generally the announcement will be –
'? Minutes to restart, Archers, x minutes to restart'.
 - As the archers are now spread along the line you may need to do the announcement twice, once at each end to make sure all the archers hear, this depends on the length of the line and how powerful your voice is.
- End of the tournament – Generally the announcement will be – Ladies and Gentlemen, can you please check, total and sign your scoresheets and leave them on the shooting line'.
 - Check with the Organiser that they are happy with this and if they want anything else announcing, for example when and where the presentation will be, if they want any help packing away the field etc.
 - Again you may need to make this announcement twice along the shooting line to make sure all archers hear you.

Practice / Sighters

- Practice / Sighters is a quiet time for Judges. It is however a good opportunity to check the targets to see how well they are holding up and if it is a World Archery round to make sure that all the arrow holes are being marked.
- If the Chief Judge has not already assigned roles you should ask them what they want you to do during the day.

Timing – Archery GB

- In Archery GB Rounds (except Indoor Record Status Rounds) there are two Options for the timing, Option one is the archer gets 2 ½ minutes for three arrows. This is not strictly timed. Option 2 is as per World Archery but without the traffic lights.
- If you suspect an archer is taking more than their time you should time them with your stop watch. Start the watch when they step onto the line and stop it when they leave the line.
- If an archer is consistently taking more than 2 ½ minutes to shoot 3 arrows you should go and speak to the archer and tell them. Mostly the archers then speed up, if they do not mark the archers scoresheet for that end – ‘Time Warning’. If they still continue to take more than 2 ½ minutes the highest scoring arrow of the end can be scored as a Miss. If it still continues to the detriment of the shoot or other archers on the target, the offending archer can be asked to retire from the shoot. This should be an absolute last resort.
- The signal to start shooting is one blast on the whistle.
- When all the archers have finished shooting and you are ready for them to go and collect their arrows it is three blasts on the whistle.
- Make sure you blow the whistle loudly and clearly so it can be heard by all.

Timing – World Archery

- In World Archery Rounds the timings are 2 minutes to shoot 3 arrows, or 4 minutes to shoot 6 arrows. At World Archery Stars and World Record Status shoots traffic lights are needed, however on some Archery GB Indoor Rounds lights might not be available.

Number of Whistles	Colour of Lights	Length of time	
2	Red	10 seconds	Start of 1 st detail. The archers may go on to the line and put an arrow on the bow but cannot put any pressure on the string
1	Green	1 ½ minutes (3 arrows) 3 ½ minutes (6 arrows)	The 1 st detail can start shooting, when they have finished shooting they leave the line
	Orange	30 seconds	Warns that there is only 30 seconds left, if there are no lights no warning is given
2	Red	10 seconds	Start of 2 nd detail. The archers may go on to the line and put an arrow on the bow but cannot put any pressure on the string
1	Green	1 ½ minutes (3 arrows) 3 ½ minutes (6 arrows)	The 2 nd detail can start shooting, when they have finished shooting they leave the line
	Orange	30 seconds	Warns that there is only 30 seconds left, if there are no lights no warning is given
3	Red	-	Archers can go to the targets

3m Line

- The 3m Line in front of the shooting line is used to determine whether or not an arrow has been shot.
- If an arrow is in front of the 3m line it is considered to have been shot and therefore scores a Miss.
- If an arrow or any part of the whole arrow is inside the 3m line it is considered not to have been shot and the archer can take another arrow and shoot that in its place.
- If no 3m line is present (at a non record status Archery GB shoot) the old rule of if you can touch the arrow with your bow with your feet staying where they are on the shooting line then it is considered not to have been shot.

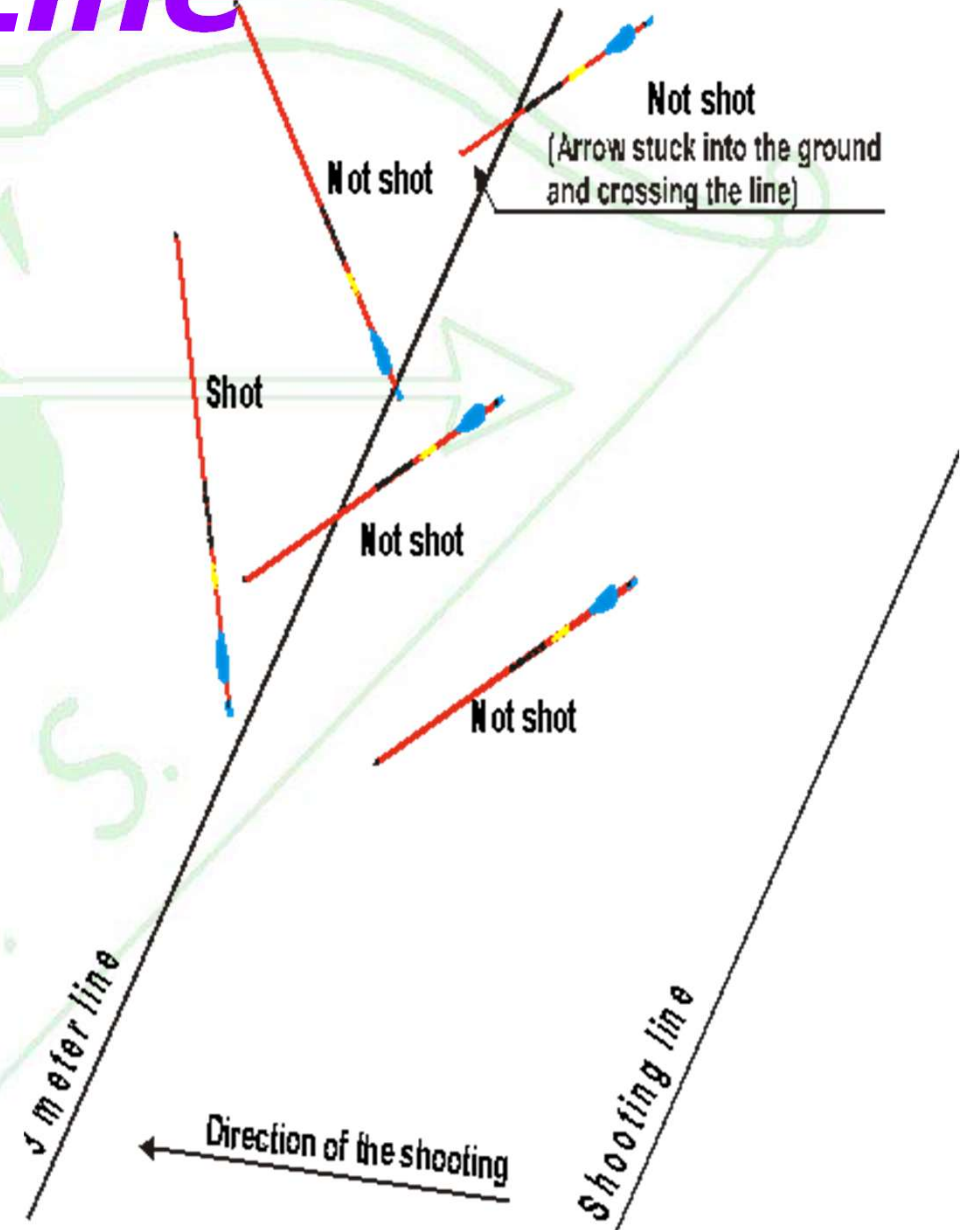

Marking Arrow Holes – World Archery

- All the arrow holes in the scoring zone need to be marked in World Archery Rounds. They need to be marked to make sure that Bouncers and Pass Throughs are dealt with correctly.
- The perfect way to mark an arrow hole is with a thin pen (not a thick marker) and make two small lines (no more than 5mm in length) at right angles to the hole. This means that if another arrow hits one of the lines the other line is still there. Most people however just put one mark, that is perfectly acceptable.
- The lines need to be quite short (less than 5mm), this is because if the line is too long and an arrow hits at the other end of the line you will not know which arrow the line is marking.
- The lines also need to be in a thin pen, if they are made using a thick marker after a while a dark spot will appear in the gold, this makes the centre easier to see.

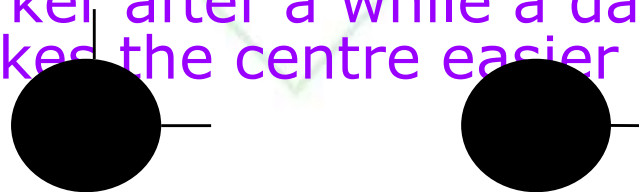

Change of Distance

- As well as announcing the change of distance and the restart time certain other tasks need to be carried out
 - Check that all targets have been moved to their new distances, this is particularly important with junior targets as it may not always be obvious.
 - Check that the targets are in line with all of the centres looking level.
 - Check that all the targets / stands / bosses are secured tightly or pegged down.
 - Take the opportunity to check the target faces and if appropriate make sure the arrow holes have been marked.
 - If faces need to be changed make sure they are put on correctly and in the right place.
 - As none of this can take place until the Working Party have finished, make sure you factor in extra time to the break between distances to check everything.

Equipment Failures – Archery GB

- If an archer has an equipment failure, they should let a Judge know straight away.
- Try to ascertain from the archer how long they think it will be until they are ready to resume shooting and if they need any assistance. Then leave them to repair the fault whilst remaining close by.
- Keep the Chief Judge informed of what is happening.
- When the archer is ready to restart shooting they can join back in and make up any arrows they have missed at the earliest opportunity, normally either at the end of the end or at the end of the distance.
- The archer has 15 minutes to correct the failure.

Equipment Failures – World Archery

- If an archer has an equipment failure, they should let a Judge know straight away.
- Try to ascertain from the archer how long they think it will be until they are ready to resume shooting and if they need any assistance. Then leave them to repair the fault whilst remaining close by.
- Keep the Chief Judge and DOS informed of what is happening.
- When the archer is ready to restart shooting they can join back in and make up any arrows they have missed at the earliest opportunity, normally either at the end of the end or at the end of the distance. They get 40 seconds per arrow.
- The maximum time or number of ends for make-up arrows to be shot is 15 minutes (following regular order of shooting and timing), or two ends of 6 arrows outdoors and three ends of 3 arrows indoors, whichever happens first.
- The process is the same for minor medical emergencies.

Bouncers – Archery GB

- If an arrow rebounds from the target the archer should call the Judge when they have finished shooting all of their other arrows.
- If you also think there has been a bouncer, ask them for a spare arrow, either make a note of the number of the arrow (making sure they only have one arrow with that number) or if the arrow does not have a number on it, make a small mark in pen on one of the fletches or on the shaft (use a fibre pen so the mark can be removed).
- Ask the archer to shoot that one arrow when everyone else on the target has finished shooting.

Bouncers – Archery GB

- Go up to the target with the archers, make sure you pick up the bounced arrow and check that it looks okay and that its position on the ground is consistent with a bouncer.
- Check the other arrows in the target to make sure the bouncer did not hit any of them and rebound. If it did, then the archer scores the value of the struck arrow and you disallow the score of the replacement arrow.
- If the archer was mistaken and there was no bouncer, then disallow the score of the replacement arrow.
- Otherwise the archer scores the value of the replacement arrow.

Bouncers – World Archery

- If an arrow rebounds from a target all archers on that target must stop shooting and call a Judge.
- When all other archers in that detail have finished shooting, the DOS will interrupt the shooting, The archer involved and Judge will go to the target.
- Pick up the bounced arrow and check that it looks okay and that its position on the ground is consistent with a bouncer. Place the arrow behind the target.
- With the archer firstly check to see if the bounced arrow stuck another arrow and rebounded from that. If it did then it scores the value of the struck arrow.

Bouncers – World Archery

- Then look for any unmarked holes in the face. If there is only one unmarked hole in the face, make a note of that value and mark the hole.
- If there is more than one unmarked hole in the face the arrow scores the value of the lowest value unmarked hole. Make a note of the value and mark all the holes. Warn the archers on that target that they need to make sure that they mark all the holes on the face.
- If there is physical evidence of where it bounced from you score that value.
- Return to the shooting line where the archers will shoot their remaining arrows, they are allowed 40 seconds per arrow. When they have finished shooting the tournament will resume.
- The Judge should go to the target and take part in the scoring, remind the archer to pick up the arrow behind the target.

Pass Throughs – Archery

GB

- If an arrow is observed to pass all the way and the Judge is satisfied it has passed through through a boss then it should be dealt with in the same way as a bouncer. But make sure the boss is replaced or packing is added before the remaining arrows are shot.
- If an arrow passes through the face but stays in the boss ask the archer to push the arrow into the boss at the same angle as it went in at, until the nock is visible on the face. Then you can score the value of the arrow. Supervise the process and the scoring of that end.

Pass Throughs – World Archery

- If an arrow passes all the way through a boss it scores the value of the unmarked hole. If more than one unmarked hole is found the value of the lowest unmarked hole is scored. Then make sure that either the boss is replaced or packing added.
- If there is physical evidence of where the arrow passed through (such as fletching marks on the face) then you score that value
- If an arrow passes through the face but stays in the boss ask the archer to pull the arrow out from the back, turn it round and reinsert it into the boss at the same angle as it went in at, until the pile is visible on the face. Then you can score the value of the arrow. Supervise the reinsertion and the scoring of that end.

Scoring an Arrow

- An arrow will be scored according to the position of the shaft in the face.
- An arrow missing the scoring zone on the face, the target or hitting another target shall be scored as a Miss (M).
- An arrow hitting another arrow and remaining embedded in that arrow will score the value of the struck arrow.
- An arrow hitting another arrow and being deflected will be scored according to the position of the shaft in the face.
- If an arrow fails to enter the boss and is hanging from the target face shooting on that boss will be stopped on that target. When the rest of the line has finished the Judge will go to the target and either push it into the boss or preferably remove the arrow from the face and record its value (and mark the hole if World Archery). It will be scored according to the position of the shaft in the face. The Judge will assist with the scoring of the end.

Checking the value of an arrow

- When archers on a target are unable to decide what an arrow scores (a line-cutter) they will ask a Judge for a decision. To make the decision you
 - Confirm with the Target which arrow it is, so you are sure, do not ask whose arrow it is.
 - Using a magnifying glass look at the arrow from two angles.
 - The looks should be quick, but not too quick, never go back for a third look.
 - Try not to touch the target face or the other arrows, but if you do it is okay.
 - If part of the line is missing or has been tucked under try to estimate where the line would have been.
 - If the shaft has broken the black line then give the higher score.
 - If you are not sure if the shaft is touching the black line, give the benefit of the doubt and give the higher score.

Checking the value of an arrow

- If the shaft has not broken the black line it is the lower score.
- When you have decided the value of the arrow turn to the archers on the target and announce clearly what it scores, for example 'That arrow scores a 9'.
- Then walk a little way from the target and make sure they score those arrows correctly. When they have scored the arrow walk away from the target.

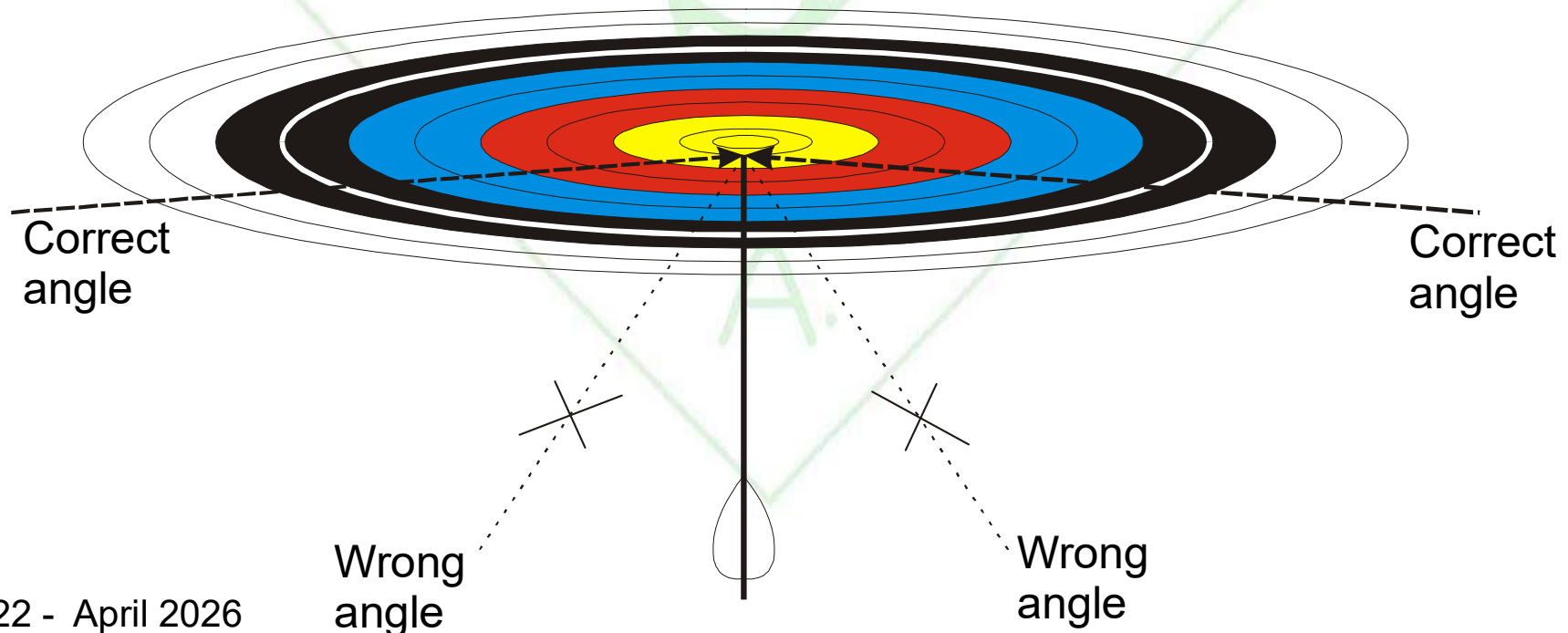

Altering the value of an arrow

- If an archer writes down the score of an arrow incorrectly, or the score they have written down looks like it has been altered, they will call a Judge to correct their scoresheet. You can only correct their scoresheet if the arrows are still in the boss (there are exceptions so please ask a senior Judge if needed as it is a case by case basis).
- All corrections should be made in red pen and put your initials by the side of the correction.
- When you are called to a target, ask for the scoreboard, and then ask the archer whose arrow is wrong to call out all of their arrows for that end, making sure they indicate their arrows.

Altering the value of an arrow

- Check all the other arrows in that end are correct and for the arrow that is wrong, cross out the wrong score and write the correct score in the box clearly. Then sign your initials either in the box provided, or at the end of the line on the scoresheet.
- Then hand the scoresheet back to the archers and walk away.
- If the archers have written down the score in the wrong order, repeat the above process, but instead of crossing out the score, underline the scores that are in the wrong order and then sign your initials.
- Please note that although the World Archery Rule Book says archers can make these types of changes themselves, we have found that this is impractical in normal competitions so we still use the old rule.

Altering the value of an arrow

Error in value	JMCH	4	10 9	8	6	24
		5	10	9	8	24
Error in descending order	JMCH	7	X	<u>10</u>	<u>X</u>	30
		8	9	9	9	27

Too many arrows have been shot

- If an archer shoots more than the required number of arrows
 - Archery GB – They will lose the value of the best arrow (s) in the target. For example if they shot 7 arrows which scored 9-9-9-7-5-3-M, they will actually score 9-9-7-5-3-M.
 - World Archery – The lowest 3 or 6 value arrows will be scored. For example if they shot 7 arrows which score 10-10-9-6-5-3-M, they will actually score 10-9-6-5-3-M.

Arrows have been shot out of time

- This only applies to rounds which are timed, that is World Archery rounds and Indoor Archery GB Record Status shoots.
- All the values of the 3 / 6 arrows are recorded on the scoresheet. The highest scoring arrow is then crossed out and replaced by an M. Then initial the change as normal. This preserves the score in case there is a dispute over whether the arrow was actually shot out of time.

Scoring on Multiple Faces

- When using multiple faces there should be one arrow in each face per archer, making 3 arrows in total.
- If more than one arrow is in one face the lowest scoring arrow is scored and the highest scoring arrow(s) are scored as misses.
- Problems come when there are multiple offences, for example 4 arrows shot and one is out of time. A 10 and a 9 in the top face, and 9 in the middle face and an 8 in the bottom face.
- When this happens you need to make sure you apply the rules in the right order to get the right result.

Scoring on Multiple Faces

- The order is
 - Deal with the value of each face first, so if there is more than one arrow in a face the lowest arrow scores. So in our example the 10 in the top face becomes a M and the 9 is scored. This makes a 9 and M in the top face, a 9 in the middle face and an 8 in the bottom face.
 - Then deal with the total number of arrows that have been shot. So if more than 3 arrows have been shot score the lowest 3. So in our example the score is 9-9-8-M, so score the lowest 3, which gives a score of 9-8-M.
 - Then deal with any arrows shot out of time. If an arrow has been shot out of time the highest scoring arrow is scored as a Miss. So in our example the score is currently 9-8-M, so the score then becomes M-8-M with the 9 being crossed out and replaced with an M.
- Do not be afraid to work through the problem on paper if needs be, this will not only help you but will help the archer understand what is happening.

Scoring on Multiple Faces

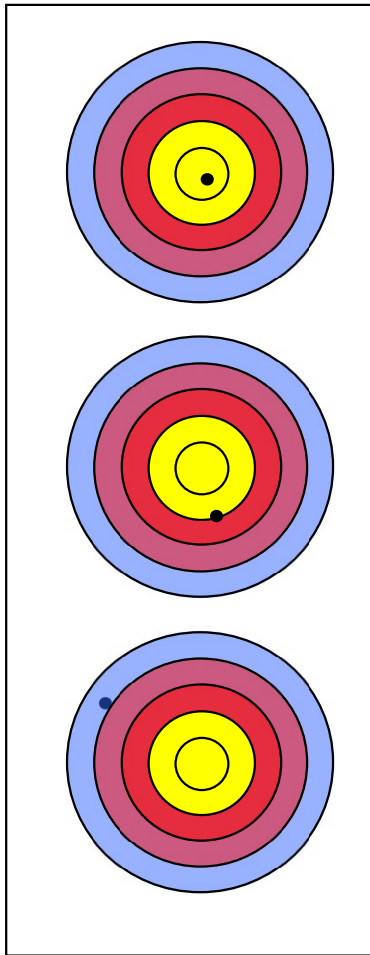

10-9-7
The bottom face is
a line cutter

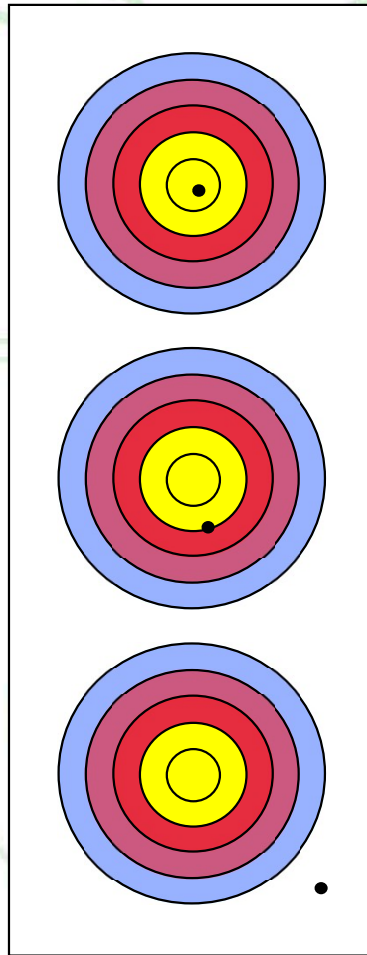

10-9-M
Only two arrows scored

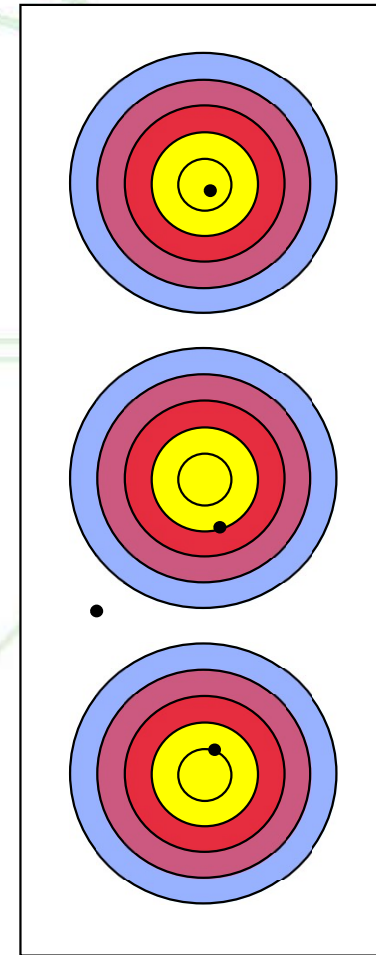

10-9-M
4 arrows were shot (10-
10-9-M) only the lowest
three are scored

Scoring on Multiple Faces

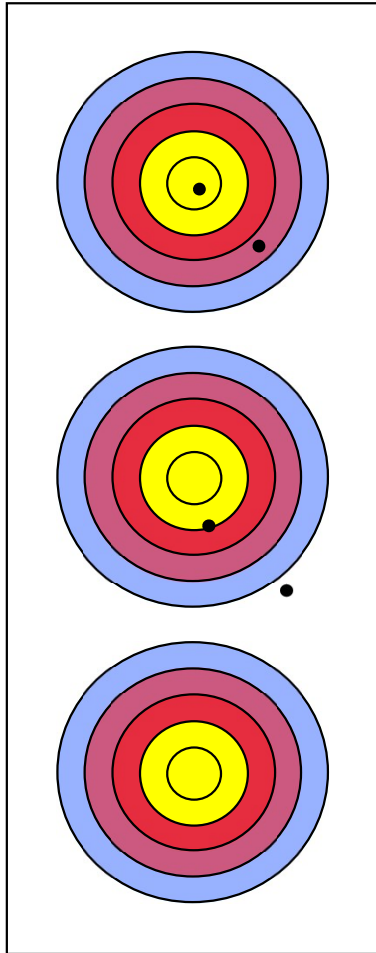

7-M-M

Top – 10-7 turns into 7-M

Giving 9-7-M-M. 4 arrows shot

Making it 7-M-M

V1.22 - April 2026

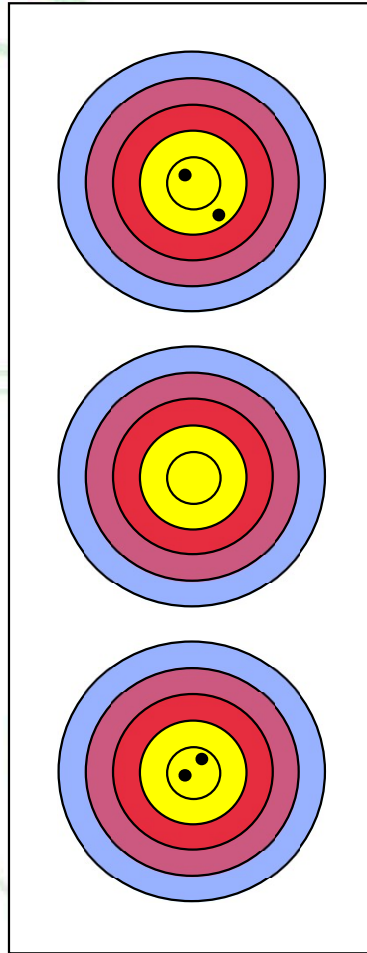

9-M-M

Top – 10-9 turns into 9-M

Bottom – 10-10 turns into 10-M

Giving 10-9-M-M. 4 arrows shot

Making it 9-M-M

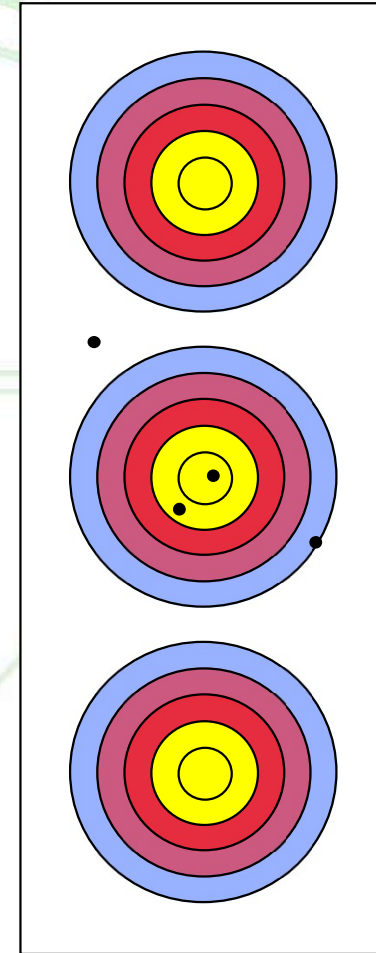

M-M-M

Middle – 10-9-6 turns into 6-M-M

, giving 6-M-M-M. 4 arrows shot. Making it

M-M-M

Scoring on Multiple Faces

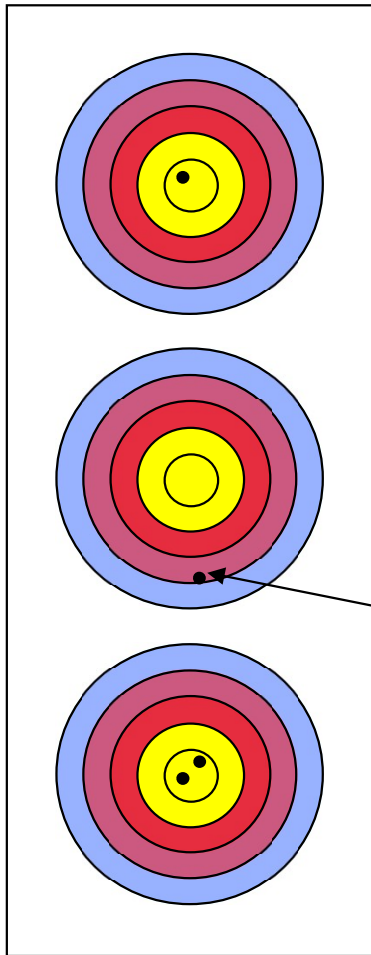

Shot
out of time

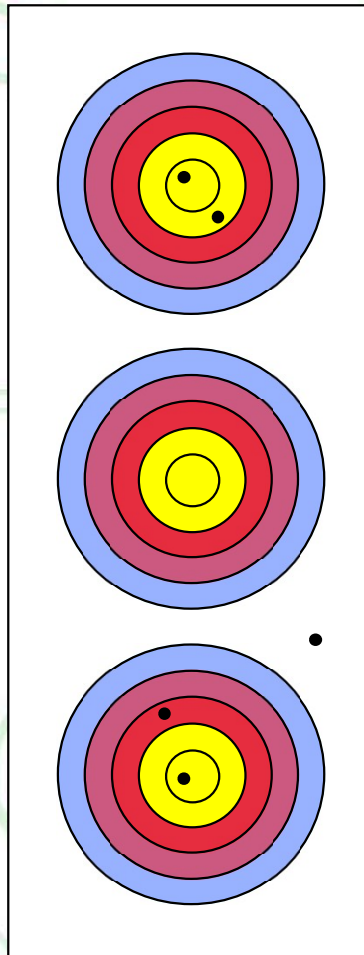

M-7-M

Bottom - 10-10 turns into 10-M
Giving 10-10-7-M. 4 arrows shot
Making it 10-7-M. One shot out
Of time making it M-7-M

V1.22 - April 2026

M-M-M

Top - 10-9 turns into 9-M
Bottom - 10-8 turns into 8-M
Making it 9-8-M-M-M. 5 arrows
shoot making it M-M-M

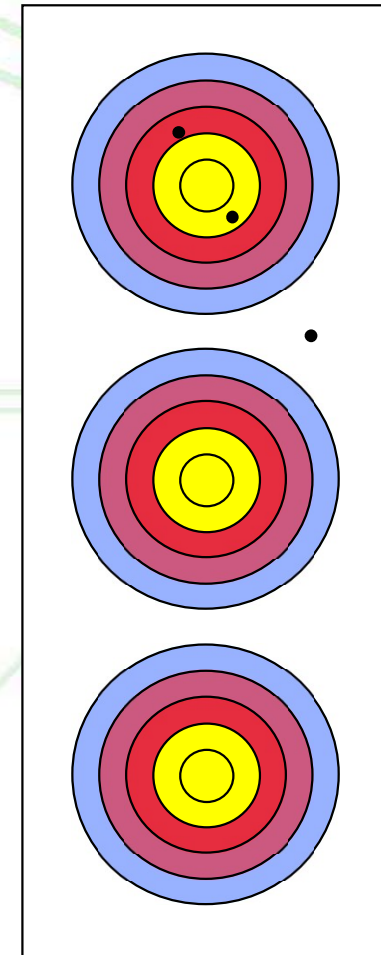

9-M-M

Top - 9-9 turns into 9-M
Making it 9-M-M

Other Penalties / Infringements

- An archer arriving late at a tournament will forfeit the number of arrows already shot, unless the Judge is satisfied they were delayed by circumstances outside of their control.
- An arrow shot before time, after practice / sighters or at any other time apart from during an end will be considered part of the next end. The archer should shoot the correct number of arrows in the next end and the highest scoring arrow will become a Miss.
- If an archer raises their bow arm in a World Archery round before the signal to start shooting has been given (in the 10 seconds) they should be warned not to do it again.
- Scopes can stay on the line as long they do not cause an obstruction to other archers and are secured
- An archer should not record their own score.

Dangerous Draws

- A Dangerous Draw is the term given to a style of drawing which could allow the arrow, if accidentally released to fly beyond the safety area.
- A good way to judge if a draw is a Dangerous Draw is if the arrow is pointing away from the target whilst there is pressure on the string.
- Dangerous Draws are hard to judge, so make sure you see it from several angles and ask the opinion of other Judges.
- If the draw is very dangerous speak to the archer straight away and explain the problem and ask them to amend their style of shooting immediately. If they refuse to change their style they can be asked to stop shooting. This is an absolute last result.
- If the draw is borderline, or is only occasionally dangerous speak to the archer at the end of the shoot and explain the problem to them and ask them to work on their style and recommend they speak to their coach on how to change their technique.

Other Duties

- Your main duty whilst Judging is to be alert to what is happening all around you. This includes on, in front and behind the shooting line.
- You also need to be available for the archers to speak to, whether it is because they have a problem, they want to chat or they just have a general query.
- You also need to liaise with the Organiser and the Field Party. Keep them informed of any problems and be ready to answer their questions. Work with them, we are all members of the same team.
- You may at times need to deal with the press and photographers. Be helpful and courteous and try to give them what they want within the limits of safety and without intruding on the archers.
- At the end of the tournament you need to stay for the prize giving and raffle as most Organisers like to publicly thank the Judges. Also make sure before you go home to thank the Organising team and the host club.



Chapter 7 – Clout Archery

Archery GB Clout

- Archery GB Outdoor Target Archery rules apply except where identified in Part 7 of the Archery GB Rules of Shooting.
- As Clout shoots are less common then it is recommended that any Judge attending a Clout shoot should re-check the rules before attending.
- Clout events can be shot on the same day and at the same venue as a Flight event without contravening Rule 304(j).
- All archers must have received instruction in Clout shooting prior to competition. To confirm this, each entry form must contain the following certificate to be signed by each archer before shooting commences:

I have received instruction in Clout shooting prior to this tournament.

Archer's signature.
- At Record Status / Tassel Award Status Clouts a formal equipment inspection must be carried out before the start of competition.

Archery GB Clout - Safety

- All reasonable steps should be taken to ensure that there will be no risk to people, animals or property if an arrow goes outside of the target area.
- Range safety shall follow the principles of Range Safety for Target Archery (Rule 302).
- For clout distances beyond 100 yards, the side safety should continue to extend from 20 yards at 100 yards, to 25 yards at 150 yards, and 30 yards at 180 yards, and remain at 30 yards thereafter.
- The overshoot distance for clout targets set beyond 100 yards will be 50 yards from the clout.

Archery GB Clout - Safety

- The bow must be drawn so that at no point during the draw must the angle the arrow makes with the horizontal be greater than the angle that is made at the point of release.
- High Trajectory Clout Shooting is BANNED except for longbows.

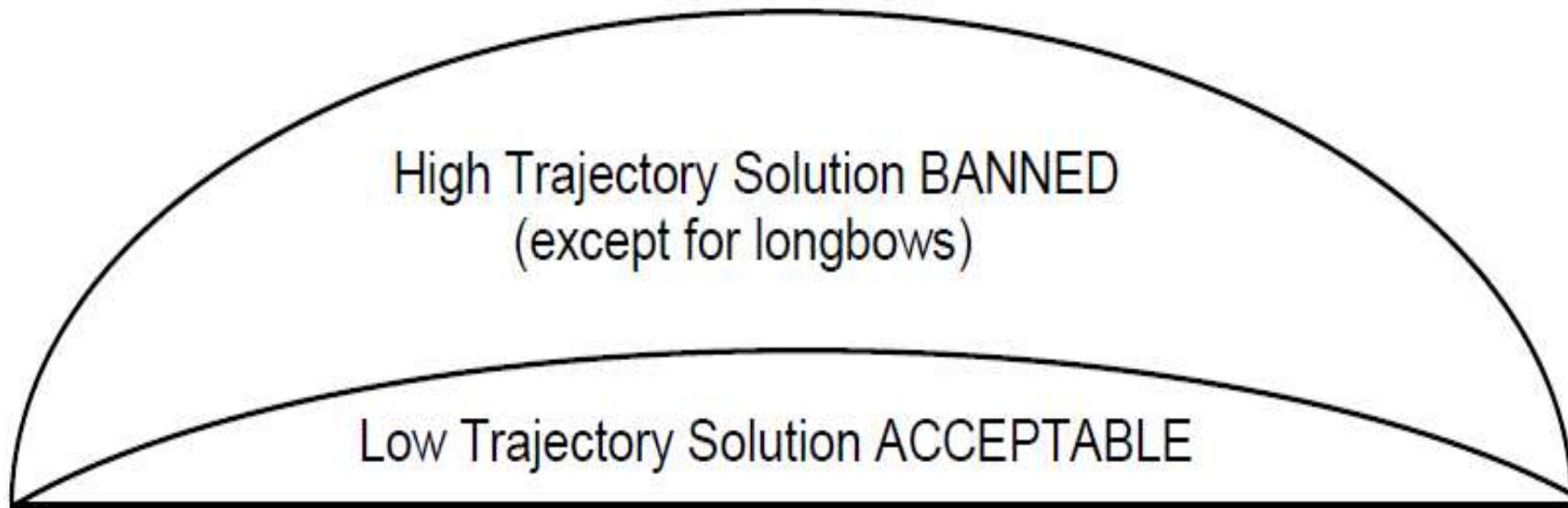

Archery GB Clout – Targets and Shooting

- **Targets**
 - The centre of each target is marked with a brightly coloured distinctive flag, it is best if each target has its own coloured flag
 - The flag is 12" square and attached to a smooth vertical stick
 - The flag should be as close as practicable to the ground, however it must be visible to the archers on the shooting line so as to allow for any undulations in the ground
 - The stick must not project above the flag
- Shooting can be one way or two way.
- There are six sighter arrows in each direction when shooting two ways.
- If shooting two ways ensure no one leaves anything at either end which could be used as a sighting point, or could be damaged by an arrow missing the target area.
- Bowstyles allowed at Clout are – Recurve (as per Rule 202), Recurve Barebow (as per Rule 204), Longbow (as per Rule 206), Compound (as per Rule 207) and Crossbow (as per Rule 210).

Archery GB Clout – Scoring

- The score is determined on the distance from where the arrow has entered the ground to the flag in the centre of the target.
 - Within a radius of -

18 inches	5 points
3 feet	4 points
6 feet	3 points
9 feet	2 points
12 feet	1 point
- The scoring zones can be identified by the radii being marked on the ground, the lines should be wholly within each circle. Or by having a non stretch tape attached to the flag stick which is marked with the various radii. If using a tape it is best to mark the ground with something to contain the whole of the scoring zone to identify the target area.

Archery GB Clout – Scoring

- The score is determined on where the arrow enters the ground, archers are not allowed to dig into the ground to try and get a higher score, but they can move the grass if needed, as long as they do not touch the arrow.
- An arrow hitting and remaining embedded in the flag shall score a 5, provided the arrow is not embedded in or touching a lower scoring zone. In this case they will score according to where the arrow has entered / touching the ground.
- If an arrow is lying loose on the ground the score is determined by the position of the point.

Archery GB Clout – Scoring

- Procedure for scoring with a tape
 - Once everyone has determined the position of their arrows in the scoring zone the scorer shall take the end of the tape and pull it taut
 - An assistant scorer should be appointed for each colour/scoring zone. If there are not enough archers then one per colour zone then people can do two colours zones, but the assistant scorer collecting the arrows in the 5/gold should do this zone only
 - The scorer then walks around the flag holding the tape at ground level and each assistant scorer picks up the arrows in their zone.
 - Once finished the arrows should be placed in distinct groups on the appropriate section of the scoring tape
 - Archers then call their scores in the normal way and collect their arrows as they do so.
- Only appointed scorers are allowed in the target area until all arrows have been withdrawn and placed on the scoring tape. Any arrow withdrawn by someone other than an appointed scorer will not be scored.
- It is a good idea to ask the colour sergeants to change colours each end to avoid anyone possibly cheating.
- The appointed scorers must not take any arrows in the target area (this includes any spare arrows in their quivers).

Archery GB Clout – Ties

Award Based On	1st Tie Break	2nd Tie Break
Score	Hits	Clouts (5s)
Hits	Score	Clouts (5s)
Clouts (5s)	Score	Hits

Archery GB Clout – Rounds

- A round consists of 36 arrows.
- UK Records are maintained for single and double rounds, both one way and two way.
- If shooting a double sighters are allowed on the second round.
- A junior may hold a record in a distance of a higher age group
- Other distances may be shot at the Organisers discretion. As long as they do not compromise Safety rules. These distances cannot be considered for UK records or 6 Clout Badges.

Archery GB Clout – Rounds

- Distances for UK Record purposes

Gentleman	9 score yards	180 yards
Ladies	7 score yards	140 yards
Junior Gents under 18	7 score yards	140 yards
Junior Gents under 16	6 score yards	120 yards
Junior Gents under 14	5 score yards	100 yards
Junior Gents under 12	4 score yards	80 yards
Junior Ladies under 18	6 score yards	120 yards
Junior Ladies under 16	5 score yards	100 yards
Junior Ladies under 14	4 score yards	80 yards

World Archery / Metric Clout

- Archery GB and World Archery / Metric Clouts are broadly similar, some of the differences are detailed here. However the safety rules are the same
- World Archery do not recognise any Clouts for Juniors, so these rounds have been added by Archery GB and are referred to as Metric Clouts.
- World Archery do not maintain records for Clouts so at present it is not possible to obtain World Record Status for a Clout Tournament or to achieve a Clout World Record.
- There is no need to mark arrows holes in World Archery Clout
- Details of the World Archery Clout can be found in Book 5 of the World Archery Rule Book.

World Archery / Metric Clout – Targets and Shooting

- Targets
 - The centre of each target is marked with a brightly coloured distinctive flag, it is best if each target has its own coloured flag
 - The flag triangular and should measure no more than 80cm in length and 30 cm in width, and attached to a round smooth vertical stick
 - The lower edge of the flag must not be more than 50 cm from the ground.
- Shooting is one way only
- There are six sighter arrows (not practice as with other World Archery Rounds)
- Ends can be shot in 3s or 6s. The maximum permitted time for 3 arrows is 2 minutes, and for 6 arrows it is 4 minutes.
- Scoring takes place after every second end of 3 arrows, or after every end if shooting in 6s

World Archery / Metric Clout - Shooting

- Shooting is done under the control of a DOS as with other World Archery Rounds.
- There will be 2 sound signals and the archers have 10 seconds to go to the line, then 1 sound signal and either 2 or 4 minutes to shoot; then the process is repeated for the second detail (if needed), then 3 sound signals to proceed with scoring.
- There is no need to have traffic lights
- The normal World Archery Rules about shooting before or after their allotted time apply
- There is no 3m line in Clout, so an arrow is considered as unshot if an archer can touch it with their bow without moving their feet; providing it has not rebounded.

World Archery / Metric Clout - Scoring

- The score is determined on the distance from where the arrow has entered the ground to the flag in the centre of the target. The total diameter of the scoring area is 15m
 - Within a radius of -

1.5 metres	5 points
3 metres	4 points
4.5 metres	3 points
6 metres	2 points
7.5 metres	1 point
- An arrow hitting and remaining embedded in the flag or pole shall score a 5.

World Archery / Metric Clout - Ties

- Ties are decided as follows
 - First by the least number of misses
 - If the tie is still undecided, then the least number of ones, and so on
 - Should all arrows be the same, the athletes are declared equal

World Archery / Metric Clout – Rounds

- A round consists of 36 arrows.
- UK Records are maintained for single and double rounds, shot one way
- For the Metric Clout where two or more rounds are shot in one day in the same venue either round will be accepted for a single round record irrespective of bow type.
- For World Archery Clout the round need not be the first round of the day
- If shooting a double sighters are allowed on the second round.

World Archery / Metric Clout – Rounds

- Distances

<u>Gender / Age</u>	<u>Compound</u>	<u>Non-Compound</u>
Gentleman	185m	165m
Ladies	165m	125m
Junior Gents under 18	165m	125m
Junior Gents under 16	125m	110m
Junior Gents under 14	110m	90m
Junior Gents under 12	90m	75m
Junior Ladies under 18	125m	110m
Junior Ladies under 16	110m	90m
Junior Ladies under 14	90m	75m

Clout Sights

- A lot of archers have created their own sights for Clout, which help them to be able to shoot with a sight.
- It is important if you see anything that looks unusual that you check it carefully against the Rule Book to see if it is legal or not. You will find some of the sights used in Clout may be deemed illegal in Target Archery as they would allow two points of aim or help with levelling (recurves), but in Clout Archery they do not offer that advantage.
- If you are not sure of anything don't be afraid to ask the archer how they use it, and with their permission take some photos and ask the Judges / Rules Working Groups for their opinion.
- Please remember that prisms are not allowed, this includes two mirrors set up in a 'periscope' style.



Chapter 8 – Head to Heads

General Notes

- Different Head to Heads may be slightly different, due to Organiser, time constraints and space but these guidelines apply to most Head to Head tournaments, including those run by the National Tournaments Working Group.
- If you are the Chairman of Judges at a Head to Head it is suggested that you spend some time with the Organiser before the competition to discuss the programme of the day with them, and ensure that everything needed is catered for, a lot of a COJs job at a Head to Head is working with the Organiser / Work Party / Announcer / DOS to ensure that the competition flows quickly and that the archers are informed of what is going on.
- The Rules for the Head to Head Round change so always consult the World Archery Rule Book before each competition to ensure you are up to date with the Rules – and don't worry they are a lot easier to understand in reality than they sound in the Rule Book.

General Notes

- It is best if the Organiser can provide the Judges with a schedule of the day which would show which targets are being used at each stage of the day, as well as which targets are available for practice. This will help plan where Judges are needed during the day as well as being available in case the archers have any questions.
- The schedule should also be posted somewhere for the archers to see.
- Another tip is for the Organiser to give each stage of the competition an identifier, for example 'Pass A' or '1/32nd MR' and this is how it is referred to by the Announcer / DOS and on the scoresheet.

Terminology

- Qualification Round - This is the round shot to determine the ranking of the archers going into the Head to Head
 - Elimination – The matches shot to eliminate the archers down to the medal matches – they are called the 1/64th, 1/32nd, 1/16th and 1/8th
 - Medal Matches / Finals – These are the Quarter Finals, Semi Finals, Bronze and Gold matches
 - MR – Mens Recurve
 - MC – Mens Compound
 - ML – Mens Longbow
 - WR – Womens Recurve
 - WC – Womens Compounds
 - WL – Womens Longbow
- (please note that Longbows are not recognised by World Archery, but a lot of Organisers let them have their own categories, but some may want them to shoot in the same categories as Recurves)

Qualification Rounds

- This is the Round used to decide which archers go into the Elimination Matches. There is no limit to the number of archers that can take part in the Qualification Round. The maximum number of archers that can go through to the Elimination Rounds is 128
- The Rounds used for Outdoors can be
 - World Archery 1440 Round
 - 70m Round for Recurves
 - 50m Round for Barebows
 - 50m Round for Compounds
- The Round used Indoors is the 18m Round
- Generally if you are shooting the entire Head to Head on the same day Outdoors then the 70m and 50m Rounds are used.
- These rounds are shot to the normal World Archery Rules

Qualification Rounds - Ties

- There are two types of Ties possible once the Qualification Round has finished
 - Non Critical Tie – this is a tie for seeding position but both archers are going to go through to the Elimination Rounds, for example a tie for position 9 and 10
 - Critical Tie – this is a tie for a cut off position, so one archer will go through to the Elimination Rounds and the other will not, for example a tie for position 64 and 65 and the Cut Off is for 64 people.

Non Critical Ties - Qualification

- Greatest number of X's
- Greatest number of 10's
- If both of these are equal then they are declared equal, their positions in Match Play charts will be decided by a disc toss.

Critical Ties - Qualification

- Both archers shoot one arrow and the archer with the highest score wins. This is on score only, 10s and Xs are not counted.
- The archers have 40 seconds to shoot the arrow in at this stage
- They shoot at neutral targets in the middle of the field, one archer per target
- If the tie is for Compounds then there will be one face in the centre of the boss for them to use.
- Both archers shoot one arrow and the highest score then wins, if the score is the same, the arrow nearest the middle wins.
- If the arrows are the same distance from the centre then the process can be repeated
- More details of this rule can be found in the World Archery Rule Book – 3 12.5.2.
- If the tie is Indoors then the archers should use the middle face of the strip.

After the Qualification Rounds

- Once the Qualification Round has been completed then it is normal practice for the Field to be closed for a short while before being reopened for practice before the Elimination Rounds. This is normally the only planned / advertised break in the day
- Once the seedings for the Eliminations have been announced liaise with the Organiser / DOS / Announcer to work out how many more ends of practice are to be allowed before the first round of the Eliminations start. This needs to be announced to the archers.
- Ensure that all scoreboards / target allocations have been collected before starting the first set of Eliminations and give the archers time to get to their target allocations (this is particularly important if there are disabled archers)

Seeding Diagrams

- The seeding diagrams can all be found in Book 2 of the World Archery Rule Book.
- The position on the shooting line is as per the seeding diagrams, so you hold the diagram with the A,B etc near to you and face the targets and use that to work out who is shooting on the left or the right.
- At some International Tournaments the top 8 archers are given a bye through the first matches and start shooting at the 1/16th Eliminations, however this does not tend to happen in UK competitions. If this is used then different seeding diagrams are used.

Preparation before the Elimination Rounds

- Before the start of the Elimination Rounds it is worth running through the rules of the matches with all the Judges to make sure they are all comfortable with the proceedings.
- Ensure that the field is all re-set, and any faces that need changing have been and all holes on competition faces have been marked.
- Make sure all Judges have some way of measuring tied arrows on them, for example callipers or dividers, these need to be able to be locked in place.
- It is often worth while holding a second assembly, even if it is just over the microphone, to remind archers of the Rules, this is particularly important if the rules have changed recently or if there are a lot of new archers.

Number of Archers per target

- In the 1/64, 1/32 and 1/16 Elimination Rounds there are 2 archers per target (for compounds the targets should be placed side by side).
- In the 1/8, 1/4, Semi, Bronze and Gold Rounds there is 1 archer per target (for compounds the target should be placed in the centre of the boss).
- If there are compounds shooting the field will have to be amended before the start of the 1/8th Round, so this a good place to have 5 minute comfort break for the archers.

Practice Targets

- As well as allowing free practice (where archers can shoot on which ever target they want) it is also important to have some practice/warm up targets available. These should be on the same field as the competition, a good idea is to have them on the end of the competition field.
- If space is limited then priority goes to the people who are shooting in the next round of matches.
- If no space is available for practice (for example indoors), then allow the archers at least one end of 'warm up' (they can shoot as many arrows as they want in 2 minutes) before the start of each match, unless they were all shooting in the match before. But you need to make sure they mark the arrow holes
- All practice must be done in the same time as the competition shooting, but the competition line has priority, so if all the matches are finished but people are still shooting on the practice targets then give the signal to proceed with scoring.
- Make sure that all announcements can be heard on the practice targets.
- Archers shooting on here are limited to shooting 5 ends of 3 arrows if Compound and 3 sets of 3 arrows if Recurve, so they don't shot any more arrows than the archers already competing.

Equipment Failures and Bouncers during Elimination Matches

- Equipment Failures and Bouncers and Minor Medical Emergencies are NOT allowed during Elimination and Finals matches.
- If an archer has an equipment failure, they can leave the line to get their spare bow or try and repair their equipment and shoot their arrows in the remaining time.
- If an archer has a Bouncer then they should call a Judge when they have finished shooting and then a Judge should proceed to the target with them, ensure the arrow was actually a bouncer and then the archer can be awarded the value of the unmarked hole. The archer must not stop shooting.
- If two archers are on the same target and they both have a bouncer, then there will be two unmarked holes in the face, so both archers will get the value of the highest unmarked hole. That way no one is disadvantaged.

Byes

- Byes – A Bye is when an archer does not have an opponent, this only happens in the first matches. If an archer has a Bye it is up to the Organiser / Chair of Judges whether they can shoot their Bye match on their assigned competition target or whether they can use the assigned practice if they want to shoot. Quite often their assigned competition targets are not available as other matches are being shot on them. The Organiser / Chair of Judges should make the decision at the start of the competition and it should be announced to all archers either at assembly or before the start of the Eliminations. No scores can be recorded for that match
- If a Bye is shoot on the competition field then the archer can only shoot 3 arrows per end / set. And a maximum of the first 3 sets can be shot if a recurve, and 5 ends of 3 arrows if a compound. If more than three arrows are shot in an end after them being warned by a Judge then the archer may be denied further practice on the competition field. But this violation will not affect their next match.

Forfeits

- Forfeits – a Forfeit is when there is a match but one of the archers does not appear. In the case of simultaneous shooting the match is forfeit if the archer is not there when the match starts, and in the case of alternating shooting the match is forfeit if the archer is not there when the order of shooting is decided. If the other archer wants to continue shooting then the same rules as used for Byes should be used. No scores can be recorded for that match and it should be shown as a forfeit match on the results.

Start of Match Announcements

- Before starting each match it is a good idea just to announce again what matches you are starting and do a quick visual check to make sure you have the archers you want, for example if it is compounds next check for anyone holding a recurve.
- Also say to the archers if anyone is not sure if they are in the right place to let a Judge know – it is a lot easier to fix a problem before it happens.
- The Judges should then let the DOS know straight away either by radio or standing on the 3m line that they have a problem, so the DOS does not start the match

Recurve/Barebow Eliminations

- These eliminations are shot using the Set System.
- They are shot over the best of 5 Sets, where each Set consists of 3 arrows shot in 2 minutes at 70m on a 122cm face. If Indoors then it is at 18m on 40cm 3 spot vertical faces.
- The winner of the Set gets 2 points, if scores are drawn each archer gets 1 point and the losing archer gets 0 points.
- The first archer to 6 points wins that match and shooting stops.
- Therefore the match could be over after 3 Sets if one archer wins the first 3 sets.
- If after 5 Sets both archers have 5 Set Points each then it is a draw.
- The normal rules about shooting before or after time, shooting more than 3 arrows etc apply.

Compound Eliminations

- Compound Eliminations are shot with the highest score winning.
- They are shot over 5 ends of 3 arrows shot in 2 minutes at 50m on a 80cm 6 zone faces. If Indoors then it is at 18m on 40cm 3 spot vertical faces.
- After 5 ends, the archer with the highest cumulative score wins. If both archers have the same score then it is a tie.
- The normal rules about shooting before or after time, shooting more than 3 arrows etc apply.

End of Match Announcements

- Once the 5 ends / Sets are completed or if only Recurves are shooting when all the individual matches are finished then it is the end of that pass/match and there are several announcements to be made.
 - Ask the archers to let a Judge know if there is a tie on their match
 - Ask them to complete and sign their scoresheets for that match
 - Ask the non winning archer to hand their scoresheet in to the organiser (or where ever the organiser would like them putting)
 - Advise the archers what the next set of matches will be, for example Gents Recurve 1/16th and that these will start in x minutes after any ties have been resolved. If an archer is not sure where to go next, ask them to speak to a Judge straight away
- If you have a tie on one of your Matches, radio the DOS straight away and indicate it by forming a T position with your arms.
- Before shooting a tie, make sure that the face(s) have an x in the centre which can be used for measuring, if one archers face needs changing then to be fair it is best to change the other archers face as well.

Ties

- As ties are more common now, it is best to conduct them under DOS control.
- Both archers get 40 seconds to shoot one arrow, which is controlled by the DOS.
- Both archers shoot one arrow. The highest score then wins, and if the score is the same, the arrow nearest the middle wins.
- If the arrows are the same distance from the centre then the process can be repeated

*please note ties are different for Indoor H2Hs

Ties

- To measure the distance from the centre verniers or callipers are needed. Measure from the edge of the arrow nearest the middle to the x of the target, then lock verniers/callipers in place and then measure the other arrow. Deciding the winner of a tie is the job of the Judge, and should not be influenced by the comments of the archers.
- If the distance to the centre of both arrows is too close to decide (for example less than 1mm) then the tie is shot again in exactly the same way.
- If the tie is Indoors then the archers should use the middle face of the strip.
- Once your tie is complete indicate this by standing in front of the targets and hold the relevant arm for the archer who won. If the tie needs to be shot again, stand with both arms out in the sign of a T.

Medal / Finals Matches

- The Final Matches are classed as 1/4, Semis, Bronze and Gold matches.
- These can either be shot all together, with the archers having 2 minutes to shoot their 3 arrows in, or using Alternating Shooting, where the archers take turns shooting one arrow each and have 20 seconds per arrow.
- Often in the UK only the Bronze and Gold matches are held using Alternating Shooting, but then only if the time and weather allow it.
- If the matches are shot all together then the Rules used for the Eliminations matches still apply and they still have 40 seconds for tied arrows.

Alternate Shooting

- Alternate shooting can either be shot as only one match at time and under DOS control, or several matches can be shot at the same time, with each match being controlled by its own Judge.
- It is most common for there to be several matches being shot at the same time under the control of individual Judges.
- Controlling a match as an individual Judge can be unnerving the first few times, so it is worth watching other Judges doing it and if possible ask a couple of archers at your club to help you practice. Each Judge develops their own way of doing them, so don't be afraid to take ideas from other Judges.

Alternate Shooting – Controlled by Individual Judge

- Before the start of each match the two archers should be called together to go through how the match is shot
 - Ask which archer was ranked higher in the Qualification Round, then ask them if they would like to shoot first or second in the first end / Set. Make a note of who is going to shoot first in the first end / set as if there is a tie they will shoot first then.
 - Explain that there will be the normal 2 beeps from the DOS and then they have 10 seconds to go to the line, then there will be 1 beep from the DOS and the time for the first archer starts.
 - They then have 20 seconds to shoot their arrow in, once they have shoot (and you have reset your stop watch), then you will say 'Shoot' or 'Go' or what ever you, the Judge, prefer to the next archer and their 20 seconds starts, and so the process continues until they have both shot 3 arrows.
 - Ask the archers what warning they would like to indicate they are running out of time, for example - 10, 5, 4, 3, 2, 1 or 5, 4, 3, 2, 1, also decide with them a signal for when their time is up, for example – stop shooting. It is best to keep these simple and for both archers to have the same.

Alternate Shooting – Controlled by Individual Judge

- When both archers are happy then let the DOS know that your match is ready to start.
- When your archers have gone to the line position yourself between the two of them about 30cm behind the shooting, or where ever you feel comfortable but so they can both hear you.
- When the 1 beep goes start your stopwatch for the start of the 1st archers 20 seconds. If an archer starts running out of time, give them the agreed countdown, and when they have run out of time give the agreed signal to them. If they shoot out of time, then they loose the highest scoring arrow of that end.
- Once the archer has shoot (or is out of time) clear your stopwatch and give the instruction for the next archer to start shooting and start your stopwatch. The archers must not raise their bow arm or shoot until you have given them the signal to start shooting, it carries the same warnings and penalties as raising your bow arm or shooting in the 10 seconds preparation time in a normal World Archery competition.
- When an archer has shot all three arrows they can leave the line.
- When all the archers have finished the signal to go and score will be given by the DOS.

Alternate Shooting – Controlled by Individual Judge

- Follow your archers to the target and if needed make score alterations or value decisions.
- Make sure the archers put their score / Set points on the flip boards if they are available.
- Find out from your archers who has the lowest cumulative score / Set points, as they will be shooting first in the next end / Set. If they are tied then the archer who shot first in the first end shoots first. Confirm who is shooting first to both archers, and don't be afraid to re-iterate this back at the waiting line as well.
- Return back to the Waiting Line but make sure you do not cross the Shooting Line before your archers have had a chance to pick up their bows.
- This process then continues until an archer has got 6 set points (recurve) or the 5 ends have finished (compounds)

Alternate Shooting – Controlled by Individual Judge

- If there is a tie at the end of the 5 ends / Sets, then there will need to be a shoot off.
- Make sure that both faces have an x on them to measure to, and if one face needs changing it is fairer to change both.
- The archers will have the 10 seconds as normal, then the archer who shot first in the first end shoots first, and has 20 seconds, then when they have shot the second archer shoots. So it is exactly the same as the rest of the match, just with one arrow instead of three.
- The process is then the same as before, where the arrow nearest the middle wins.

Alternate Shooting – DOS Control

- DOS control is very similar to Individual Judge control except it is one match at the time.
- The archers still need to be called together to establish who is shooting first.
- Each archer has their own countdown timer, so when the archer has shot, or their time has run out, the DOS starts the clock for the second archer, there is not normally a beep when the countdown timer starts, but it depends on the system used.

Shooting with Blinds

- When shooting under DOS Control (one match at a time) then you can also use Blinds if wanted.
- Blinds are structures which are placed near the targets, there can be one, or one per target. These should be quite large and be thick enough to stop an arrow.
- In the Blinds can be a Judge, an Agent per archer, one or two scorers if wanted, and at least two runners.
- When the end / Set has finished and the signal to score has been given the Judge, Agents and Scorer(s) come out of the blinds, perform the scoring and this saves the archers walking to the targets.

Shooting with Blinds - Duties

- Judge – The Judge is there to oversee the scoring and if necessary make line decisions or alter arrow values. It is very important that the Judge has a radio, so if there are any problems they can communicate with the line Judge, DOS or COJ.
- Agents – these are representatives of the archer, and as such check the scores being recorded, pull the arrows, mark the arrow holes, use the flip boards and hand the arrows to the Runners
- Scorers – if used they record the scores, this can either be done at the target as normal, or as each arrow hits the target. If scorers are not available then the Judge can perform their duties
- Runners – the runners take the arrows back to the archers, so whilst the second end/Set is being scored the runners return the arrows that were shot in the first end, and so on. Therefore it is important to have two sets of runners. Ideally there should be 4 runners, so each archer has their own.
- It is also important to have a supply of target faces in the blinds, in the case of ties
- **IT IS VERY IMPORTANT THAT EVERYONE STAYS WITHIN THE BLINDS UNTIL THE 3 BEEPS ARE HEARD, EVEN IF YOU HAVE SEEN ENOUGH ARROWS GO DOWN TO THE TARGET. IF YOU ARE NOT SURE IF IT IS SAFE TO COME OUT, RADIO.**

Crowd Participation

- Unlike Archery GB Rounds, crowd participation is allowed, and should be encouraged to a degree.
- The normal practice is that people can cheer and shout encouragement whilst the archers are getting ready to shoot, but not whilst the archer is at full draw.
- Likewise any cheering and encouragement should be kept 'clean' and anyone shouting anything unacceptable or offensive should be asked politely to stop
- In the same way, it is perfectly acceptable for music to be played at all times, although it is usual to turn it off or down whilst people are shooting. Again the music should be acceptable to all people and should not cause offence.



Chapter 9 – Additional Information

Record Claims

- National, World Archery Europe/Continental and World Record Claims as well as Rose Awards and World Archery Stars/Target Awards can be claimed using the Record Status Booklet.
- When two or more rounds/sessions are shot in a day, records can be claimed on any round/session – it does not have to be the first one shot.
- Regional, County and Club records have to be claimed by the archer themselves through the right organisation, although they will probably need their scoresheet.

Record Status Report

- All Record Status and above level tournaments have a Record Status booklet which is sent to the Organiser electronically which includes the Record / Award claim forms.
- The Chair of Judges needs to complete a Judge Report which is online and is submitted directly to AGB.
- This should be done as a group of Judges so everyone gets input.
- If there are any major problems or if there is something you don't want to put on the online report any Judge can submit an email to judges@archerygb.org with the details. It is advisable if you think a complaint might arise from the tournament

Record Status Report

- The Record Status Booklet is now available as an electronic document. Each type of competition has a relevant Judge Report form - Target, Field, Clout etc
- The report forms can be
 - Filled in on the day using the Tournament Organiser's computer/device or your own.
 - Emailed to you by the TO for you to fill out and send back to the TO/AGB.
 - Printed off by the TO, filled in by you on the day and posted/scanned in back to the office by the TO.
- The TOs are sent confirmation showing what level of status the event has been awarded and for which rounds, which can be checked.

Six/Three Gold Ends

- Whilst a Judge is no longer needed to witness a Six or Three Gold End, most archers still like you to witness them.
- If you are called to witness one, sign the score sheet next the end putting '6/3 gold end' and then initial it.
- To claim their six/three gold end the archer will need to complete a form which can either be found in the Record Status booklet, from the Organiser or from the Archery GB Office. They will need to send in their scoresheet.
- Depending on the level of the competition you may want to announce that they have got a six/three gold end, for example if it is a friendly club shoot.

Abbreviations / Terms

- Archery GB (AGB) – UK Governing Body. Also known as GNAS – Grand National Archery Society
- World Archery (WA) – World Governing Body. Also known as FITA - Federation Internationale de Tir a l'Arc –
- World Archery Europe (WAE) – European Governing Body. Also known as EMAU - European and Mediterranean Archery Union
- COJ – Chairman of Judges
- DOS – Director of Shooting
- WRS – World Record Status
- RS – Record Status
- JLO – Judge Liaison Officer
- FOP – Field of Play
- 5 zone scoring – Archery GB Imperial Scoring – 9, 7, 5, 3, 1
- 10 zone scoring – World Archery and Archery GB Metric Scoring – 10, 9, 8, 7, 6, 5, 4, 3, 2, 1

Useful Websites

- Archery GB Website
 - www.archerygb.org
- World Archery Website
 - www.worldarchery.org
- World Archery Europe Website
 - www.archeryeurope.org
- SCAS Website
 - www.scasarchery.org.uk

Useful Contacts

- Archery GB Office
 - 01952 677 888
- Contact details for the AGB Judge Working Group*
 - judges@archerygb.org
- Current SCAS Judges Chairman **
 - Miss Hannah Brown
- Current SCAS Judge Liaison Officer **
 - Mrs Katy Lipscomb – 07803 314 638

* Check the Archery GB website for the up to date contacts

** Check the SCAS website for the up to date contacts

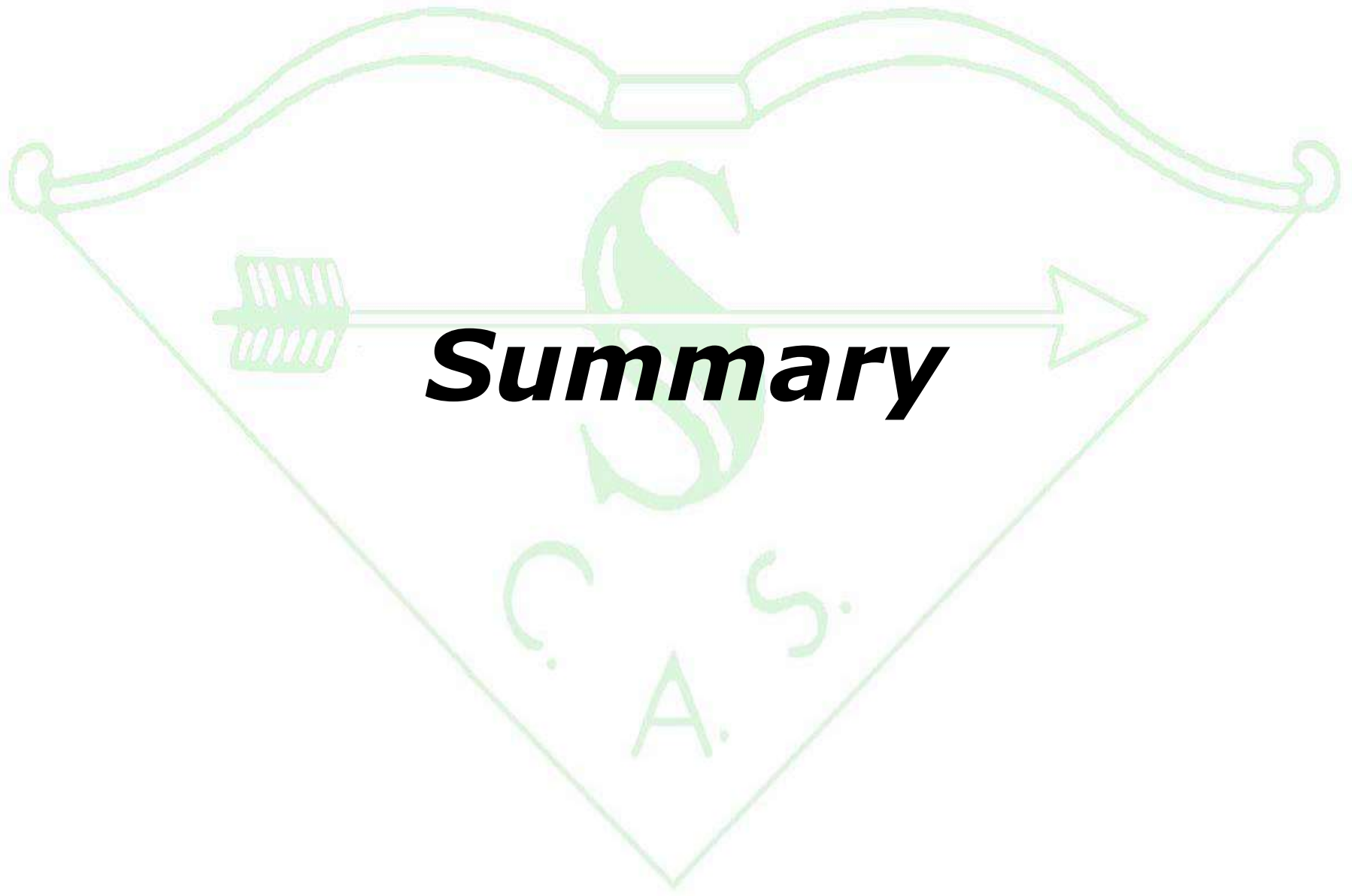

Summary

Summary

- We hope you have found this information useful and that it will help you in your Judging career.
- Please remember that this presentation does not contain everything and is only the rules at a given point in time, so make sure you read the Rule Books and keep up to date with any changes.
- If you think anything needs adding to this presentation or changing, please let us know. We want this presentation to develop over time.
- Remember if you have any questions or problems, please ask someone, we are all here to help you and we want you to achieve your Judging potential.

Golden Rules

- **Relax and Enjoy yourself** – remember this is supposed to be fun, and if you enjoy yourself the archers will enjoy themselves too.
- **Always try to be fair** – whenever you make a decision try to make sure it is fair and that no archer is unfairly advantaged or unfairly disadvantaged. Be protective not punitive and give the benefit of the doubt.
- **Use the Rules** – always be careful to make sure you use the Rule Book and never make up a rule particularly when it comes to penalties. Try to always bear in mind the intention of a rule when applying it.